

GB Gas oil burners

Progressive two-stage or modulating operation



RL B10

CODE	MODEL	TYPE
20032782 - 20034201	RL 28/M	663 M
20032794 - 20034202	RL 38/M	664 M
20032797 - 20034203	RL 50/M	665 M

1	Declaration	3
2	Information and general warnings	4
2.1	Information about the instruction manual	4
2.1.1	Introduction	4
2.1.2	General dangers	4
2.1.3	Danger: live components	4
2.2	Guarantee and responsibility	5
2.3	Guidance for the use of bio fuel blends up to 10%	5
2.3.1	Information and general instructions	6
2.3.2	Product Disclaimer Statement	6
3	Safety and prevention	7
3.1	Introduction	7
3.2	Safety warnings	7
3.3	Basic safety rules	7
3.4	Personnel training	7
4	Technical description of the burner	8
4.1	Burner designation	8
4.2	Models available	8
4.3	Technical data	9
4.4	Packaging - Weight	10
4.5	Overall dimensions	10
4.6	Firing rates	11
4.7	Burner description	12
4.8	Standard equipment	12
5	Installation	13
5.1	Notes on safety for the installation	13
5.2	Handling	13
5.3	Preliminary checks	13
5.4	Installer/Service notes for the use of Gas oil with Bio blends up to 10%	14
5.5	Operating position	14
5.6	Boiler plate	14
5.7	Blast tube length	15
5.8	Securing the burner to the boiler	15
5.9	Nozzle installation	16
5.9.1	Choice of nozzle	16
5.9.2	Recommended nozzles	16
5.9.3	Nozzle assembly	16
5.10	Gas oil supply	17
5.10.1	Double-pipe circuit	17
5.10.2	The loop circuit	17
5.10.3	Single-pipe circuit	18
5.11	Hydraulic connections	18
5.12	Pump	19
5.12.1	Technical data	19
5.12.2	Pump priming	19
6	Electrical system	20
6.1	Notes on safety for the electrical wiring	20
6.2	Electrical connections	20
6.3	Calibration of thermal relay	21
7	Start-up, calibration and operation of the burner	22
7.1	Notes on safety for the first start-up	22
7.2	Burner firing	22

7.3	Burner calibration	22
7.3.1	Combustion head setting	22
7.3.2	Servomotor	22
7.3.3	MAX power	23
7.3.4	MIN power	24
7.3.5	Intermediate power	24
7.4	Oil pressure switch.....	24
7.5	Burner operation	25
7.5.1	Burner starting	25
7.5.2	Steady state operation	25
7.5.3	Firing failure	25
7.5.4	Firing failure	25
7.6	Final checks	26
8	Maintenance	27
8.1	Notes on safety for the maintenance	27
8.2	Maintenance programme	27
8.2.1	Maintenance frequency.....	27
8.2.2	Checking and cleaning.....	27
8.2.3	Fuel pump and/or couplings replacement	28
8.3	Opening the burner	28
9	Faults - Possible causes - Solutions.....	29
A	Appendix - Accessories (optional).....	31
B	Appendix - Electrical panel layout.....	32

1 Declaration

Declaration of conformity in accordance with ISO / IEC 17050-1

Manufacturer:	RIELLO S.p.A.	
Address:	Via Pilade Riello, 7 37045 Legnago (VR)	
Product:	Gas oil burners	
Model:	RL 28-38-50/M	
These products are in compliance with the following Technical Standards:		
EN 267		
EN 292		
and according to the European Directives:		
MD	2006/42/EC	Machine Directive
LVD	73/23/EEC - 2006/95/EC	Low Voltage Directive
EMC	89/336/EEC - 2004/108/EC	Electromagnetic Compatibility

The quality is guaranteed by a quality and management system certified in accordance with UNI EN ISO 9001.

Declaration of Conformity A.R. 8/1/2004 & 17/7/2009 – Belgium

Manufacturer:	RIELLO S.p.A. 37045 Legnago (VR) Italy Tel. ++39.0442630111 www.rielloburners.com		
Distributed by:	RIELLO NV Ninovesteenweg 198 9320 Erembodegem Tel. (053) 769 030 Fax. (053) 789 440 e-mail. info@riello.be URL. www.riello.be		
It is hereby certified that the apparatuses specified below conform with the model of the type described in the CE conformity declaration and they are produced and placed in circulation in conformity with the provisions defined in L.D. dated January 8, 2004 and July 17, 2009.			
Type of product:	Gas oil burners		
Model:	RL 28-38-50/M		
Regulation applied:	EN 267 and A.R. dated January 8, 2004 - July 17, 2009		
Measured value:	RL 28/M	CO max:	20 mg/kWh
		NOx max:	143 mg/kWh
	RL 38/M	CO max:	28 mg/kWh
		NOx max:	154 mg/kWh
	RL 50/M	CO max:	20 mg/kWh
		NOx max:	142 mg/kWh

Legnago, 31.03.2010

Mr. G. Conticini
Burners Division Department
RIELLO S.p.A.



2 Information and general warnings

2.1 Information about the instruction manual

2.1.1 Introduction

The instruction manual supplied with the burner:

- is an integral and essential part of the product and must not be separated from it; it must therefore be kept carefully for any necessary consultation and must accompany the burner even if it is transferred to another owner or user, or to another system. If the manual is lost or damaged, another copy must be requested from the Technical Assistance Service of the area;
- is designed for use by qualified personnel;
- offers important indications and instructions relating to the installation safety, start-up, use and maintenance of the burner.

Symbols used in the manual

In some parts of the manual you will see triangular DANGER signs. Pay great attention to these, as they indicate a situation of potential danger.

2.1.2 General dangers

The **dangers** can be of **3 levels**, as indicated below.



Maximum danger level!
This symbol indicates operations which, if not carried out correctly, cause serious injury, death or long-term health risks.



This symbol indicates operations which, if not carried out correctly, may cause serious injury, death or long-term health risks.



This symbol indicates operations which, if not carried out correctly, may cause damage to the machine and/or injury to people.

2.1.3 Danger: live components



This symbol indicates operations which, if not carried out correctly, lead to electric shocks with lethal consequences.

Other symbols



ENVIRONMENTAL PROTECTION

This symbol gives indications for the use of the machine with respect for the environment.

- This symbol indicates a list.

Abbreviations used

Ch.	Chapter
Fig.	Figure
Page	Page
Sec.	Section
Tab.	Table

Delivery of the system and the instruction manual

When the system is delivered, it is important that:

- the instruction manual is delivered to the user by the system manufacturer, with the recommendation to keep it in the room where the heat generator is to be installed.
- The instruction manual shows:
 - the serial number of the burner;

.....

- the address and telephone number of the nearest Assistance Centre.

.....

- The system supplier must carefully inform the user about:
 - the use of the system;
 - any further tests that may be required before activating the system;
 - maintenance, and the need to have the system checked at least once a year by a representative of the manufacturer or another specialised technician.
To ensure a periodic check, the manufacturer recommends the drawing up of a Maintenance Contract.

2.2 Guarantee and responsibility

The manufacturer guarantees its new products from the installation date, in accordance with the regulations in force and/or the sales contract. At the moment of the first start-up, check that the burner is integral and complete.



Failure to observe the information given in this manual, operating negligence, incorrect installation and carrying out of non authorised modifications will result in the annulment by the manufacturer of the guarantee that it supplies with the burner.

In particular, the rights to the guarantee and the responsibility will no longer be valid, in the event of damage to things or injury to people, if such damage/injury was due to any of the following causes:

- incorrect installation, start-up, use and maintenance of the burner;
- improper, incorrect or unreasonable use of the burner;
- intervention of unqualified personnel;
- carrying out of unauthorised modifications on the equipment;
- use of the burner with safety devices that are faulty, incorrectly applied and/or not working;
- installation of untested supplementary components on the burner;
- powering of the burner with unsuitable fuels;
- faults in the fuel supply system;
- continuation of use of the burner when a fault has occurred
- repairs and/or overhauls incorrectly carried out;
- modification of the combustion chamber with inserts that prevent the regular development of the structurally established flame;
- insufficient and inappropriate surveillance and care of those burner components most likely to be subject to wear and tear;
- the use of non-original components, including spare parts, kits, accessories and optional;
- force majeure.

The manufacturer furthermore declines any and every responsibility for the failure to observe the contents of this manual.

Riello warranty is subject to correct burner, appliance and application matching, and set up in line with Riello's instructions and guidelines. All components within the hydraulic circuit suitable for bio fuel use and supplied by Riello will be identified as Bio compatible. No warranty is given in relation to the use of components which are not so identified with bio fuel blends. If in any doubt please contact Riello for further advice.

If any Riello burners are used with fuel with a bio content >10% then the components within the hydraulic circuit maybe affected and are not covered under warranty. The hydraulic circuit consists of;

- Pump
 - Hydraulic ram (where applicable)
 - Valve block
 - Flexible oil lines (considered as a consumable component)
1. Irrespective of any warranty given by Riello in relation to normal use and manufacturing defects, when fuels not meeting the relevant standards are used, or where fuel storage issues have not been addressed correctly, or the equipment used is not compatible, if failures occur which are directly or indirectly attributed to such issues and/or to the non-observance of this guidance, then no warranty or liability is implied or accepted by Riello.
 2. Riello have carefully chosen the specification of the bio compatible components including the flexible oil lines to protect the pump, safety valve and nozzle. The Riello warranty is dependent upon the use of Riello genuine components including the oil lines, being used.
 3. Riello warranty does not cover defects arising from incorrect commissioning or servicing by non Riello employed service engineers, and any issues impacting the burner arising from external site related issues.

2.3 Guidance for the use of bio fuel blends up to 10%

Background

With increasing focus on renewable and sustainable energy requirements, Bio fuel usage is set to increase. Riello is committed to promoting energy conservation and the use of renewable energy from sustainable resources including liquid bio fuels, however there are some technical aspects that must be considered at the planning stage of using such fuels to reduce the potential for equipment failure or the risks of fuel leakage.

Liquid Bio fuel is a generic description used for oil that can come from numerous feed stocks including recycled cooking oils. These types of oils have to be considered and treated differently from standard mineral or fossil fuels, as they are generally more acidic, hygroscopic and less stable.

Due to this, a holistic approach is needed from the specification of the liquid Bio fuel, the storage of the fuel, its oil supply line and ancillary equipment, and very importantly the oil filtration and the burner itself. The specification for FAME (Fatty Acids Methyl Ester) liquid Bio fuel is critical to reliable equipment operation.

It is a minimum requirement that the fuel blend (up to 10% Bio) is obtained with gasoil in accordance with the relevant EN standards, regional regulations and FAME in accordance with EN 14214. It is also important that the fuel blends meet the require-

ments related to operational environment conditions within the relevant EN standards.

When choosing your Riello oil products where you know Bio fuels will be in use, please make sure that a Bio compatible burner and/or components have been supplied. If an existing burner is to be used with a liquid Bio fuel then a kit may be required to make it compatible and the guidance notes enclosed concerning oil storage and filtration must be adhered to. The end user is responsible for the thorough verification of the potential risks associated with the introduction of a bio fuel blend and the suitability of the appliances and installation applicable.

Irrespective of any warranty given by Riello in relation to normal use and manufacturing defects, when fuels not meeting the relevant standards are used, or where fuel storage issues have not been addressed correctly, or the equipment used is not compatible, if failures occur which are directly or indirectly attributed to such issues and/or to the non-observance of this guidance, then no warranty or liability is implied or accepted by Riello.

2.3.1 Information and general instructions

To ensure consistency, the supplier of the fuel must be able to demonstrate compliance with a recognised Quality Control and management system to ensure high standards are maintained within the storage, blending and delivery processes. The installation oil storage tank and its ancillaries must also be prepared BEFORE liquid Bio fuel is introduced. Checks and preparation should include;

- For new installations, make sure that all materials and seals in the oil storage and supply line to the burner are compatible with Bio fuels. For all installations, there must be a good quality bio compatible oil filter at the tank and then a secondary filter of 100 Microns protecting the burner from contamination.
- If an existing oil storage tank is to be used then in addition to the materials checks as detailed above, it will be essential that the tank is first inspected for condition and checked for water or other contamination. Riello strongly recommends that the tank is cleaned and oil filters replaced prior to Bio fuel delivery. If this is not completed then due to the hydroscopic nature of Bio fuel, it will effectively clean the tank, absorb water present which in turn will result in equipment failure that is not covered by the manufacturer's warranty.
- Depending on the capacity of the oil storage tank and oil usage, fuels may remain static within the tank for some considerable time and so Riello recommends that the oil distributor is consulted regarding the use of additional Biocides within the fuel to prevent microbial growth from occurring within the tank. Riello suggests that fuel suppliers and or service companies are contacted for guidance on fuel filtration. Special attention should be applied to fuel applications where oil may be stored for long periods of time.
- The burner must be set according to the appliance application and commissioned checking that all combustion parameters are as recommended in the appliance technical manual.
- Riello recommends that the in line and burner oil pump filters are inspected and if required replaced at least every 4 months during burner use, before the burner start-up following a long period of discontinue operation and even more frequently where contamination has occurred. Particular attention is needed when inspecting and checking for fuel leakages from seals, gaskets and hoses.

2.3.2 Product Disclaimer Statement

CAREFULLY READ THE FOLLOWING DISCLAIMER. YOU ACCEPT AND AGREE TO BE BOUND BY THIS DISCLAIMER BY PURCHASING RIELLO BIO COMPATIBLE BURNERS AND/OR COMPONENTS.

Although the information and recommendations (hereinafter "Information") in this guidance is presented in good faith, believed to be correct and has been carefully checked, Riello (and its subsidiaries) makes no representations or warranties as to the completeness or accuracy of the Information. Information is supplied upon the condition that the persons receiving same will make their own determination as to its suitability for their purposes prior to use. In no event will Riello (and its subsidiaries) be responsible for damages of any nature whatsoever resulting from the use of or reliance upon Information.

Other than set forth herein, Riello (and its subsidiaries) makes no additional warranties with respect to the bio compatible burner, either express or implied, including that of merchantability or fitness for a particular purpose or use.

In no event shall Riello (and its subsidiaries) be liable for any indirect, incidental, special or consequential damages including, without limitation, loss of profits, damages for loss of business profits, business interruption, loss of business information, loss of equipment, or other pecuniary loss or compensation for services whether or not it is advised of the possibility of such damages.

With the exception of injuries to persons, Riello's liability is limited to the customer's right to return defective/non-conforming products as provided by the relevant product warranty.

3 Safety and prevention

3.1 Introduction

The burners have been designed and built in compliance with current regulations and directives, applying the known technical rules of safety and envisaging all the potential danger situations.

It is necessary, however, to bear in mind that the imprudent and clumsy use of the equipment may lead to situations of death risk for the user or third parties, as well as the damaging of the burner or other items. Inattention, thoughtlessness and excessive confidence often cause accidents; the same applies to tiredness and sleepiness.

It is a good idea to remember the following:

- The burner must only be used as expressly described. Any other use should be considered improper and therefore dangerous.

In particular:

it can be applied to boilers operating with water, steam, diathermic oil, and to other uses expressly named by the manufacturer;

the type and pressure of the fuel, the voltage and frequency of the electrical power supply, the minimum and maximum deliveries for which the burner has been regulated, the pressurisation of the combustion chamber, the dimensions of the combustion chamber and the room temperature must all be within the values indicated in the instruction manual.

- Modification of the burner to alter its performance and destinations is not allowed.
- The burner must be used in exemplary technical safety conditions. Any disturbances that could compromise safety must be quickly eliminated.
- Opening or tampering with the burner components is not allowed, apart from the parts requiring maintenance.
- Only those parts detailed as available as spare parts by the Manufacturer can be replaced.

3.2 Safety warnings

The dimension of the boiler's combustion chamber must respond to specific values, in order to guarantee a combustion with the lowest polluting emissions rate.

The Technical Service Personnel will be glad to give you all the information for a correct matching of this burner to the boiler.

This burner must only be used for the application it was designed for.

The manufacturer accepts no liability within or without the contract for any damage caused to people, animals and property due to installation, adjustment and maintenance errors or to improper use.

3.3 Basic safety rules

- Children or inexperienced persons must not use the appliance.
- Under no circumstances must the intake grids, dissipation grids and ventilation vents in the installation room be covered up with cloths, paper or any other material.
- Unauthorised persons must not attempt to repair the appliance.
- It is dangerous to pull or twist the electric leads.
- Cleaning operations must not be performed if the appliance is not disconnected from the main power supply.

- Do not clean the burner or its parts with inflammable substances (e.g. petrol, alcohol, etc.). The cover must be cleaned with soapy water.
- Do not place anything on the burner.
- Do not block or reduce the size of the ventilation vents in the installation room.
- Do not leave containers and inflammable products or combustible materials in the installation room.

3.4 Personnel training

The user is the person, body or company that has acquired the machine and intends to use it for the specific purpose. He is responsible for the machine and for the training of the people working around it.

The user:

- undertakes to entrust the machine exclusively to suitably trained and qualified personnel;
- must take all the measures necessary to prevent unauthorised people gaining access to the machine;
- undertakes to inform his personnel in a suitable way about the application and observance of the safety instructions. With that aim, he undertakes to ensure that everyone knows the use and safety instructions for his own duties;

- must inform the manufacturer if faults or malfunctioning of the accident prevention systems are noticed, along with any presumed danger situation.
- Personnel must always use the personal protective equipment envisaged by legislation and follow the indications given in this manual.
- Personnel must observe all the danger and caution indications shown on the machine.
- Personnel must not carry out, on their own initiative, operations or interventions that are not within their province.
- Personnel must inform their superiors of every problem or dangerous situation that may arise.
- The assembly of parts of other makes, or any modifications, can alter the characteristics of the machine and hence compromise operating safety. The manufacturer therefore declines any and every responsibility for any damage that may be caused by the use of non-original parts.

4 Technical description of the burner

4.1 Burner designation

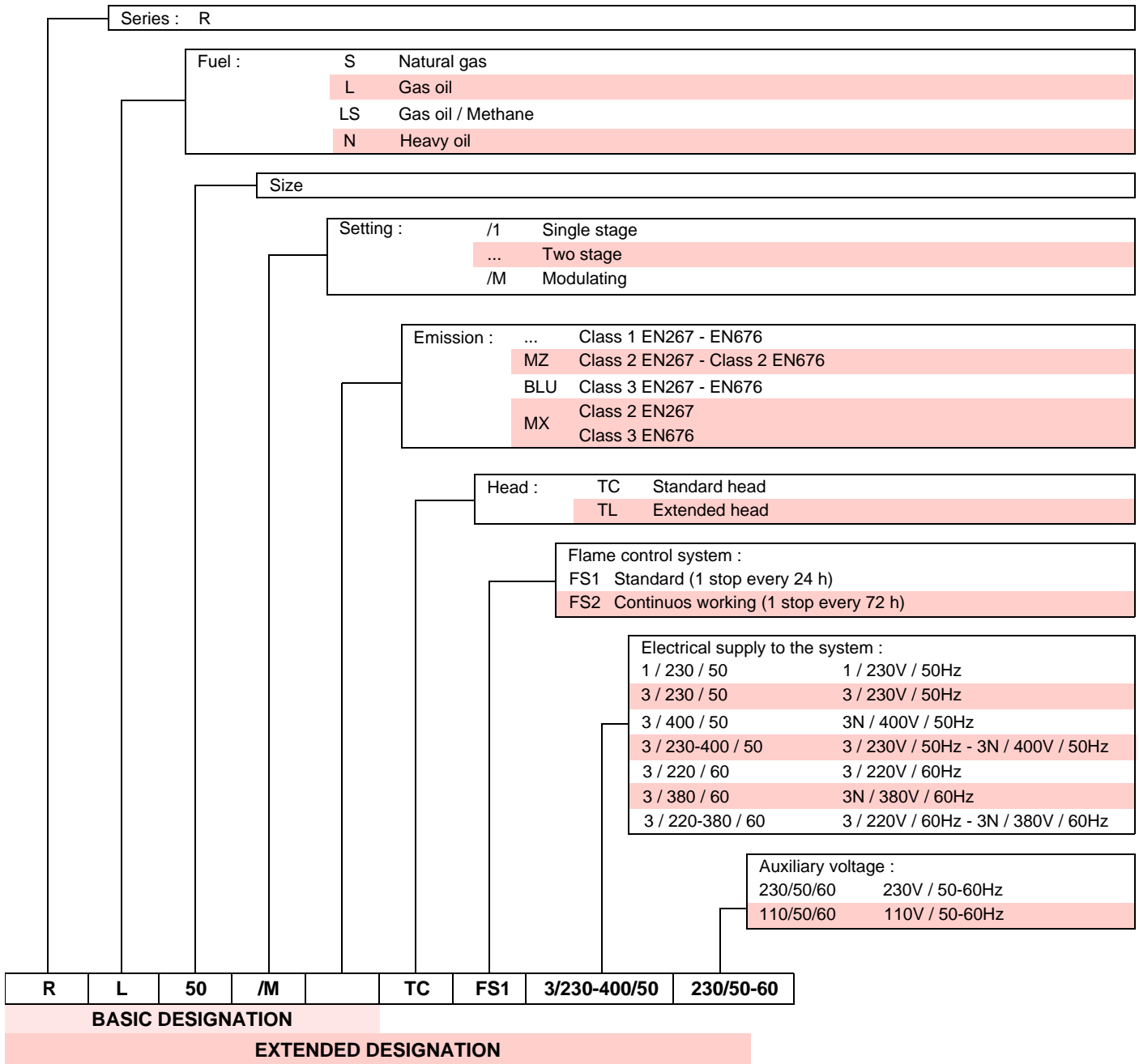

4.2 Models available

Designation	Head	Electrical supply	Code
RL 28/M	TC	1/230/50	20032782
RL 28/M	TL	1/230/50	20034201
RL 38/M	TC	3/230-400/50	20032794
RL 38/M	TL	3/230-400/50	20034202
RL 50/M	TC	3/230-400/50	20032797
RL 50/M	TL	3/230-400/50	20034203

4.3 Technical data

Model			RL 28/M	RL 38/M	RL 50/M
Type			663 M	664 M	665 M
Output ⁽¹⁾ Delivery ⁽¹⁾	Max.	kW	166 - 332	237 - 450	296 - 593
		Mcal/h	143 - 286	204 - 387	255 - 510
	Min.	kg/h	14 - 28	20 - 38	25 - 50
		kW	90 - 166	101 - 237	130 - 296
		Mcal/h	76.5 - 143	87 - 204	112 - 255
		kg/h	7.5 - 14	8.5 - 20	11 - 25
Fuel			Gas oil and Blends of gas oil and bio fuel (FAME in accordance with EN 14214) up to 10%		
Gas oil	net calorific value		11.86		
			10.2 (10.200 kcal/kg)		
	density		0.82 - 0.85		
	viscosity at 20 °C		6 (1.5 °E - 6 cSt)		
		kWh/kg			
		Mcal/kg			
		kg/dm ³			
		mm ² /s max			
Operation			<ul style="list-style-type: none"> - On-Off (min 1 stop each 24 hours). These burners are also fitted for the continuous operation, if they are equipped with the control box LANDIS type LOK 16.250 A27 (interchangeable with the burner control box LANDIS LAL 1.25). - Progressive two-stage (modulating by Kit). 		
Nozzles		number	1 (nozzle with return)		
Standard applications			Boilers: water, steam, diathermic oil		
Ambient temperatur		°C	0 - 40		
Combustion air temperature		°C max	60		
Electrical supply		V/Ph/Hz	230/1/50	230-400/3/50	
Auxiliary power supply		V/Ph/Hz	230/1/50		
Electric motor		rpm	2800	2800	2800
		W	300	450	650
		V	220/240	220/240 - 380/415	220/240 - 380/415
		A	2,4	2 - 1.2	3 - 1.7
Ignition transformer		V1 - V2 I1 - I2	230 V - 2 x 5 kV 1.9 A - 30 mA		
Pump	delivery (at 12 bar)	kg/h	74	99	99
	pressure range	bar	10 - 20	10 - 20	10 - 20
	fuel temperatur	° C max	60	60	60
Electrical power consumption		W max	400	600	800
Electrical protection			IP 44		
Noise levels ⁽³⁾		dB(A)	68	70	75

Tab. A

⁽¹⁾ Reference conditions: ambient temperature 20°C - Barometric pressure 1013 mbar - Altitude 0 m a.s.l.

⁽³⁾ Sound pressure measured in manufacturer's combustion laboratory, with burner operating on test boiler and at maximum rated output.

4.4 Packaging - Weight

- The burners are shipped in cardboard boxes with the maximum dimensions shown in Tab. B.
- The weight of the burner complete with packaging is indicated in Tab. B.

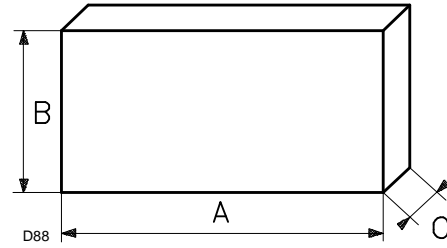

Fig. 1

mm	A	B	C	kg
RL 28/M	872	550	540	39
RL 38/M	872	550	540	41
RL 50/M	872	550	540	42

Tab. B

4.5 Overall dimensions

The maximum dimensions of the burner are given in Fig. 2.

Bear in mind that inspection of the combustion head requires the burner to be opened and the rear part withdrawn on the slide bars.

The maximum dimension of the burner, without casing, when open is give by measurement H.

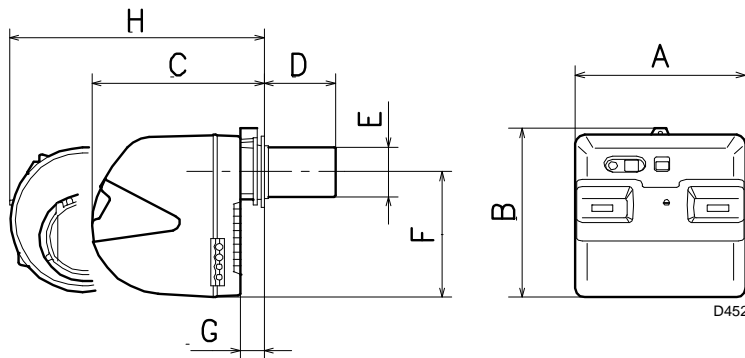

Fig. 2

mm	A	B	C	D (1)	E	F	G	H (1)
RL 28/M	476	474	468	241 - 351	140	352	52	672 - 807
RL 38/M	476	474	468	241 - 351	140	352	52	672 - 807
RL 50/M	476	474	468	241 - 351	152	352	52	672 - 807

Tab. C

(1) Blast tube: short - long

4.6 Firing rates

During operation, burner output varies between:

- minimum output : area A
- maximum output : area B

The work point may be found by plotting a vertical line from the desired delivery and a horizontal line from the pressure in the combustion chamber.

The intersection of these two lines is the work point which must lie within area A, for MIN output, and within area B, for MAX output.



WARNING

The firing rate value (Fig. 3) has been obtained considering an ambient temperature of 20 °C, an atmospheric pressure of 1013 mbar (approx. 0 m above sea level), and with the combustion head adjusted as shown on page 22.

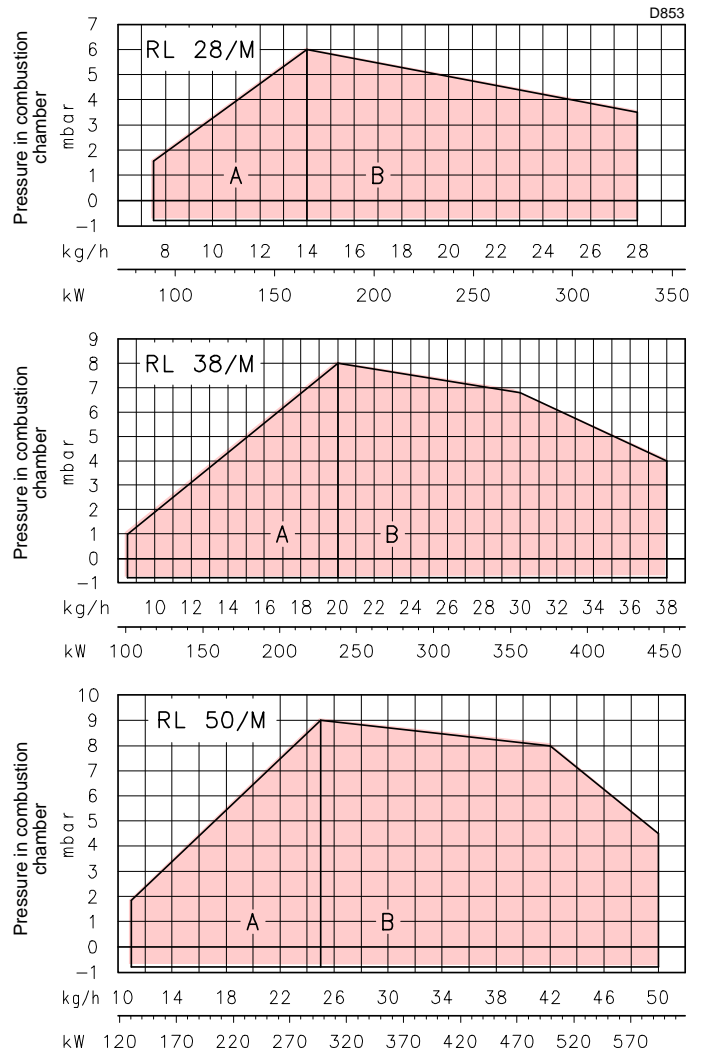

Fig. 3

4.7 Burner description

- 1 Ignition electrodes
- 2 Combustion head
- 3 Screw for combustion head adjustment
- 4 Photocell for flame presence control
- 5 Screw for fixing fan to flange
- 6 Servomotor provides adjustment of fuel delivery regulator and of air gate valve. When the burner is not operating the air gate valve is fully closed in order to reduce heat dispersion from the boiler due to the flue draught which draws air from the fan suction inlet.
- 7 Slide bars for opening the burner and inspecting the combustion head
- 8 Pump delivery valve (safety valve)
- 9 Pump delivery valve
- 10 Valve on nozzle return
- 11 Oil pressure switch
- 12 Pump
- 13 Plate prearranged to drill 4 holes for the passage of hoses and electrical cables.
- 14 Supplementary air gate valve
- 15 Non-drip nozzle holder
- 16 Fan pressure test point
- 17 Boiler mounting flange
- 18 Flame stability disk
- 19 Flame inspection window
- 20 Power switch for different operation: automatic - manual - off
Button for: power increase - power reduction
- 21 Motor contactor and thermal cut-out with reset button (RL 38-50/M)
- 22 Motor capacitor (RL 28/M)
- 23 Control box with lock-out pilot light and lock-out reset button
- 24 Terminal strip
- 25 Air gate valve
- 26 Pump pressure adjustment
- 27 Pressure gauge for pressure on nozzle return
- 28 Pressure regulator on nozzle return
- 29 Extensions for slide bars 7)

Two types of burner failure may occur:

Control Box Lock-out:

if the control box 23)(Fig. 4) pushbutton lights up, it indicates that the burner is in lock-out. To reset, press the pushbutton.

Motor trip (RL 38-50/M):

release by pressing the pushbutton on thermal relay 21)(Fig. 4).

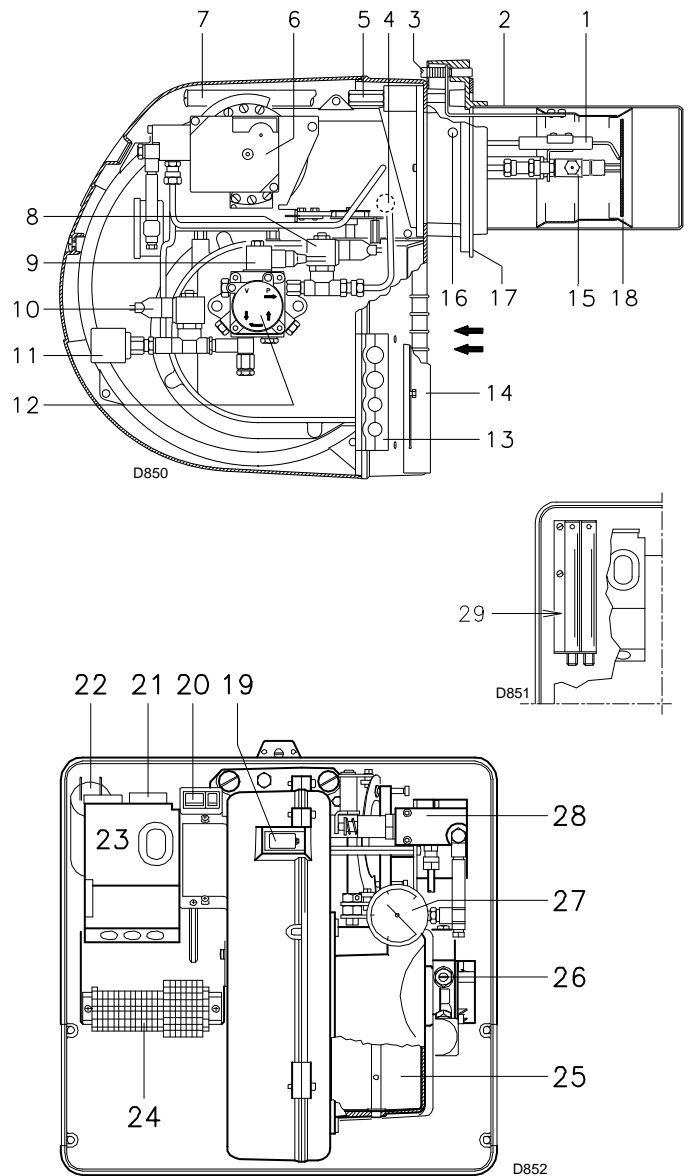

Fig. 4

4.8 Standard equipment

- 1 - Flange gasket
- 2 - Hoses
- 2 - Gaskets for flexible hoses
- 2 - Nipples for flexible hoses
- 1 - Thermal insulation screen
- 2 - Extensions 29)(Fig. 4) for slide bars 7)
(for models with 351 mm blast tube)
- 4 - Screws to secure the burner flange to the boiler M 8 x 25
- 3 - Fairleads for electrical connections (RL 28/M)
- 4 - Fairleads for electrical connections (RL 38-50/M)
- 1 - Instruction booklet
- 1 - Spare parts list



In case of use with gas oil containing up to 10% Bio blend, it will be essential to use flexible oil lines suitable for bio fuel use. Please contact Riello for further information.

5 Installation

5.1 Notes on safety for the installation

After carefully cleaning all around the area where the burner will be installed, and arranging the correct lighting of the environment, proceed with the installation operations.



All the installation, maintenance and disassembly operations must be carried out with the electricity supply disconnected.



The installation of the burner must be carried out by qualified personnel, as indicated in this manual and in compliance with the standards and regulations of the laws in force.

5.2 Handling

The packaging of the burner includes a wooden platform, so it is possible to move the burner (still packaged) with a transpallet truck or fork lift truck.



The handling operations for the burner can be highly dangerous if not carried out with the greatest attention: keep any unauthorised people at a distance; check the integrity and suitability of the available means of handling. Check also that the area in which you are working is empty and that there is an adequate escape area (i.e. a free, safe area to which you can quickly move if the burner should fall). When handling, keep the load at not more than 20-25 cm from the ground.



After positioning the burner near the installation point, correctly dispose of all residual packaging, separating the various types of material. Before proceeding with the installation operations, carefully clean all around the area where the burner will be installed.

5.3 Preliminary checks

Checking the consignment



After removing all the packaging, check the integrity of the contents. In the event of doubt, do not use the burner; contact the supplier.



The packaging elements (wooden cage or cardboard box, nails, clips, plastic bags, etc.) must not be abandoned as they are potential sources of danger and pollution; they should be collected and disposed of in the appropriate places.



R.B.L.	A			
TIPO/TYP/TYPE	B	C		
N°	D	F		H
	E			
G				
RIELLO S.p.A. I-37045 Legnago (VR)				
S8232				

Fig. 5

Checking the characteristics of the burner

Check the identification label of the burner, showing:

- the model (A)(Fig. 5) and type of burner (B);
- the year of manufacture, in cryptographic form (C);
- the serial number (D);
- the data for electrical supply and the protection level (E);
- the absorbed electrical power (F);
- the types of fuel used and the relative supply pressures (G);
- the data of the burner's minimum and maximum output possibilities (H) (see Firing rate)



The output of the burner must be within the boiler's firing rate;



A burner label, or any other component, that has been tampered with, removed or is missing, prevents the definite identification of the burner and makes any installation or maintenance work difficult.

5.4 Installer/Service notes for the use of Gas oil with Bio blends up to 10%

- During the burner installation, check that the gasoil and bio fuel blends are in accordance with Riello specifications (please refer to the chapters "Technical Data" and "Guidance for the use of bio fuel blends up to 10%" within the burner technical manual).
- If a Bio blend is in use the installer must seek information from the end user that their fuel supplier can evidence that the blends of fuel conform to the relevant standards.
- Check that the materials used in the construction of the oil tank and ancillary equipment are suitable for bio fuels, If not these must be upgraded or replaced with Bio compatible parts.
- Particular attention should be given to the oil storage tank and supply to the burner. Riello recommends that existing oil storage tanks are cleaned, inspected and any traces of water are removed BEFORE bio fuel is introduced (Contact the tank manufacturer or oil supplier for further advice). If these recommendations are not respected this will increase the risk of contamination and possible equipment failure.
- In line oil filters should be replaced making sure that they are Bio compatible. Riello recommends a good quality bio compatible oil filter at the tank and a secondary 100 micron filter are used to protect the burner pump and nozzle from contamination.
- The burner hydraulic components and flexible oil lines must be suitable for bio fuel use (check with Riello if in doubt). Riello have carefully chosen the specification of the bio compatible components including the flexible oil lines to protect the pump, safety valve and nozzle. The Riello warranty is dependent upon the use of Riello genuine components including the oil lines, being used. The burner must be commissioned and combustion parameters set to appliance manufacturer's recommendations.
- Regularly check visually for any signs of oil leakage from seals, gaskets and hoses.
- It is strongly recommended that with Bio fuel use, oil filters are inspected and replaced every 4 months. More regularly where contamination is experienced.
- During extended periods of non operation and/or where burners are using oil as a standby fuel, it is strongly recommended that the burner is put into operation for short periods at least every three months.

5.5 Operating position

The burner is designed to work only in the positions 1, 2, 3 and 4. Installation 1 is preferable, as it is the only one that allows performing maintenance operations as described in this manual. Installations 2, 3 and 4 permit operation but make maintenance and inspection of the combustion head difficult, page 27.



Any other position could compromise the correct working of the appliance.

Installation 5 is prohibited for safety reasons.

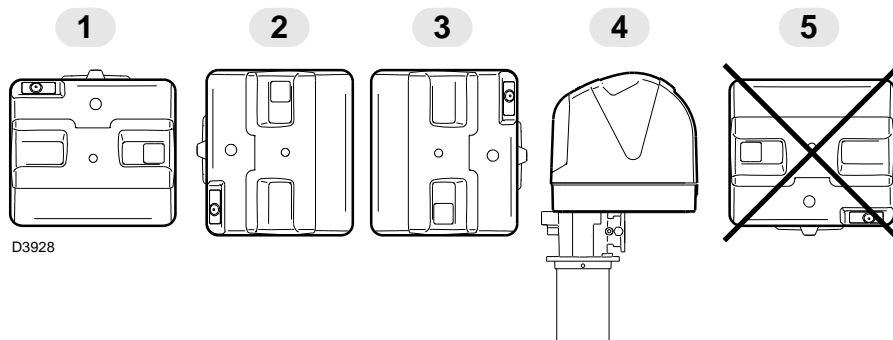

Fig. 6

5.6 Boiler plate

Drill the combustion chamber locking plate as shown in Fig. 7. The position of the threaded holes can be marked using the thermal screen supplied with the burner.

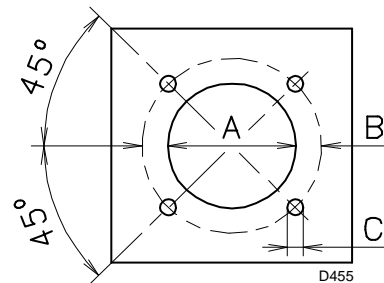

Fig. 7

mm	A	B	C
RL 28/M	160	224	M 8
RL 38/M	160	224	M 8
RL 50/M	160	224	M 8

Tab. D

5.7 Blast tube length

The length of the blast tube 7)(Fig. 8) must be selected according to the indications provided by the manufacturer of the boiler, and in any case it must be greater than the thickness of the boiler door complete with its fettling.

The range of lengths available, L (mm), is as follows:

Blast tube 7)(Fig. 8)	Short	Long
RL 28/M	241	351
RL 38/M	241	351
RL 50/M	241	351

For boilers with front flue passes 10)(Fig. 8) or flame inversion chambers, protective fettling in refractory material 8) must be inserted between the boiler fettling 9) and the blast tube 7).

This protective fettling must not compromise the extraction of the blast tube.

For boilers having a water-cooled front the refractory fettling 8)-9) is not required unless it is expressly requested by the boiler manufacturer.

5.8 Securing the burner to the boiler

Disassemble the blast tube 7)(Fig. 8) from the burner 4) by proceeding as follows:

- remove the screws 2) from the two slide bars 3).
- Remove the screw 1) fixing the burner 4) to the flange 5).
- Withdraw the blast tube 7) complete with flange 5) and slide bars 3).
- Secure flange 5) to the boiler plate interposing the supplied gasket 6).

- Use the 4 screws provided after having protected the thread with antiscuffing products.



The burner-boiler seal must be airtight.

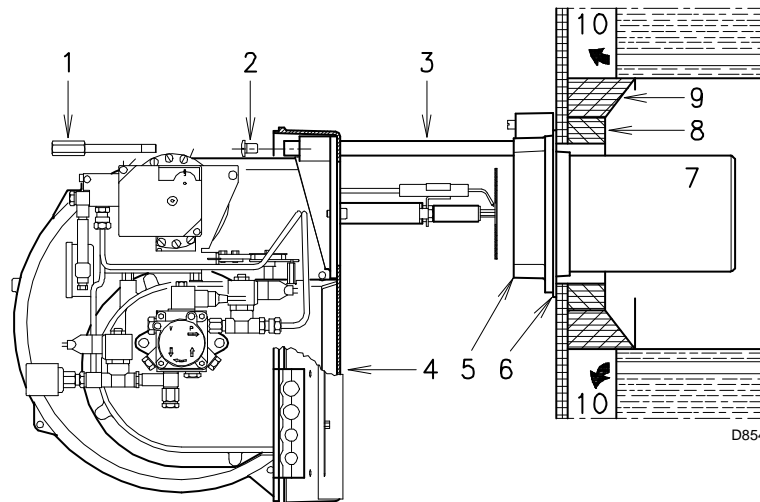

Fig. 8

5.9 Nozzle installation

5.9.1 Choice of nozzle

The burner complies with the emission requirements of the EN 267 standard.

In order to guarantee that emissions do not vary, recommended and/or alternative nozzles specified by Riello in the Instruction and warning booklet should be used.



It is advisable to replace nozzles every year during regular maintenance operations.



The use of nozzles other than those specified by Riello S.p.A. and inadequate regular maintenance may result into emission limits non-conforming to the values set forth by the regulations in force, and in extremely serious cases, into potential hazards to people and objects.

The manufacturing company shall not be liable for any such damage arising from nonobservance of the requirements contained in this manual.

Tighten the screws 2) on the slide bars 3) and screw 1) that attaches the burner to the flange.

If it proves necessary to change a nozzle with the burner already fitted to the boiler, proceed as outlined below:

- pull back the burner on its slide bars as shown in Fig. 8 at page 15;
- remove the nuts 1)(Fig. 12) and the disk 2).
- Use spanner 3)(Fig. 12) to change the nozzles.

Nozzle must be chosen among those in Tab. E:

1	2	3	4
A3	kg/h	bar	bar
15	13	20	17
20	20	20	17
30	24	20	15
40	30	20	16
50	33	20	16
60	42	20	16
70	50	20	15

Tab. E

Key (Tab. E)

- 1 Type A3 Bergonzo nozzle
- 2 MAX nozzle delivery
- 3 Pump delivery pressure
- 4 MAX pressure on nozzle return

In case an intermediate delivery between the two values indicated in Tab. E is required, a nozzle with higher delivery must be chosen.

Delivery reduction will be obtained by means of the pressure regulator.

5.9.2 Recommended nozzles

Type A3 or A4 Bergonzo nozzles - 45° angle.

5.9.3 Nozzle assembly

At this stage of installation the burner is still disassembled from the blast tube; it is therefore possible to fit the nozzle with the box spanner 1)(Fig. 9), fitting the spanner through the central hole in the flame stability disk.



Do not use any sealing products such as gaskets, sealing compound, or tape.

Be careful to avoid damaging the nozzle sealing seat.

Make sure that the electrodes are positioned as shown in Fig. 10. Finally remount the burner 4)(Fig. 11) on the slide bars 3) and slide it up to the flange 5), keeping it slightly raised to prevent the flame stability disk from pressing against the blast tube.

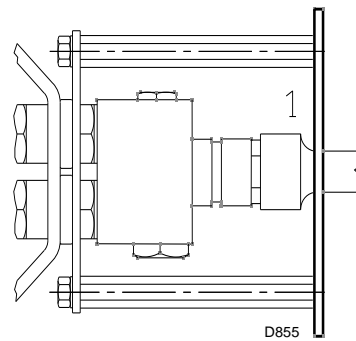

Fig. 9

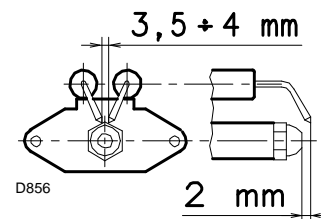

Fig. 10

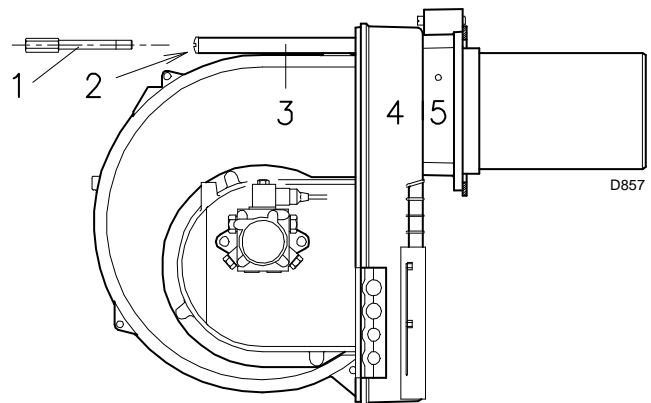

Fig. 11

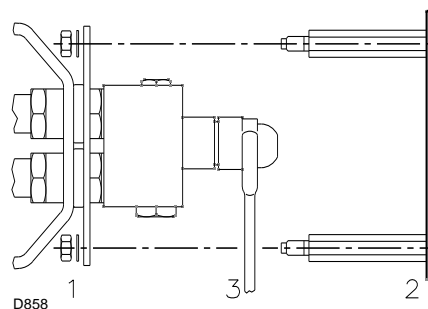

Fig. 12

5.10 Gas oil supply



Where gas oil containing bio diesel is in use, it is recommended to avoid over oxygenation of the blended fuels.

Where at all possible avoid the use of two pipe systems where the circulated fuel is returned to the tank.

If this cannot be avoided make sure that the return pipe is normally below the surface of the fuel level within the storage tank.



In case of use with gas oil containing up to 10% Bio blend, it will be essential to use flexible oil lines suitable for bio fuel use.

Please contact Riello for further information.



It is strongly recommended a periodic check of the pump pressure operation (annually or better every six months, if the burner operation is continuous).



You are advised to use additional filters on the fuel supply line.

Riello recommends a good quality fuel filter at the tank (Fig. 13 - Fig. 14) and a secondary filter (100 μ for gas oil and 15 μ for kerosene) are used to protect the burner pump and nozzle from contamination.

In case of Biodiesel use, pay attention to install Biocompatible filters.

5.10.1 Double-pipe circuit

The burner is equipped with a self-priming pump which is capable of feeding itself within the limits listed in the Tab. F.

The tank higher than the burner A (Fig. 13)

Distance "P" must not exceed 10 meters in order to avoid subjecting the pump's seal to excessive strain; distance "V" must not exceed 4 meters in order to permit pump self-priming even when the tank is almost completely empty.

The tank lower than the burner B (Fig. 13)

Pump depression values higher than 0.45 bar (35 cm Hg) must not be exceeded because at higher levels gas is released from the fuel, the pump starts making noise and its working life-span decreases.

It is good practice to ensure that the return and suction lines enter the burner from the same height; in this way it will be less probable that the suction line fails to prime or stops priming.

5.10.2 The loop circuit

A loop circuit consists of a loop of piping departing from and returning to the tank with an auxiliary pump that circulates the fuel under pressure.

A branch connection from the loop goes to feed the burner.

This circuit is extremely useful whenever the burner pump does not succeed in self-priming because the tank distance and/or height difference are higher than the values listed in the Tab. F.

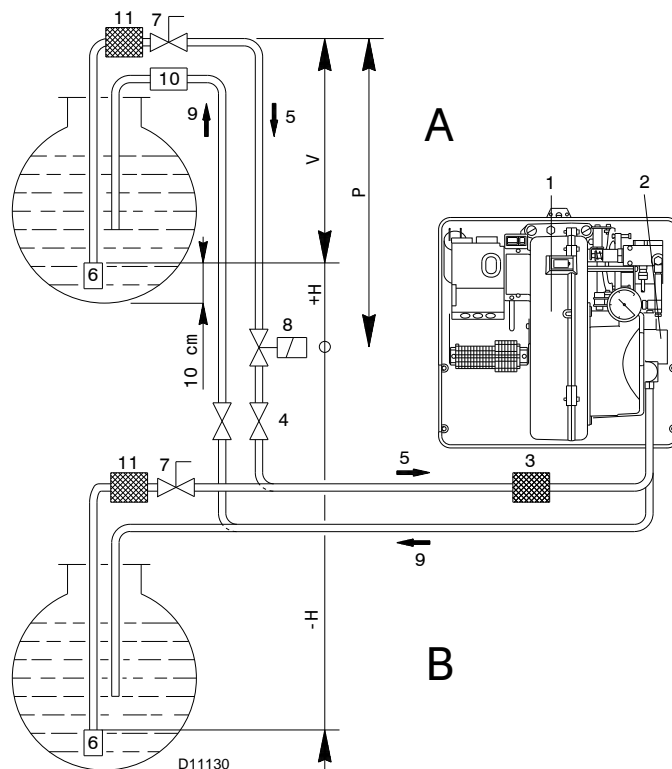

Fig. 13

Key (Fig. 13)

- H Pump/Foot valve height difference
- L Piping length
- ∅ Inside pipe diameter
- 1 Burner
- 2 Pump
- 3 Filter
- 4 Manual on/off valve
- 5 Suction line
- 6 Foot valve
- 7 Rapid closing manual valve remote controlled (only Italy)
- 8 On/off solenoid valve (only Italy)
- 9 Return line
- 10 Check valve (only Italy)
- 11 Tank filter

+/- H (meters)	L (meters)					
	RL 28/M			RL 38-50/M		
	∅ mm			∅ mm		
	10	12	14	10	12	14
+ 4,0	63	144	150	51	112	150
+ 3,0	55	127	150	45	99	150
+ 2,0	48	111	150	39	86	150
+ 1,0	40	94	150	32	73	144
+ 0,5	37	86	150	29	66	132
0	33	78	150	26	60	120
- 0,5	29	70	133	23	54	108
- 1,0	25	62	118	20	47	96
- 2,0	17	45	88	13	34	71
- 3,0	10	29	58	7	21	46
- 4,0	-	12	28	-	8	21

Tab. F

5.10.3 Single-pipe circuit

In order to obtain single-pipe working it is necessary to unscrew the return hose, remove the by-pass screw 6)(Fig. 29) and then screw the plug 7)(Fig. 29).

The distance "P" must not exceed 10 meters in order to avoid subjecting the pump's seal to excessive strain; the distance "V" must not exceed 4 meters.

For the priming pump loosen the screw 3)(Fig. 16) in order to bleed off the air contained in the suction line and wait until the fuel flows out.

Key (Fig. 14)

H Pump/Foot valve height difference

L Piping length

∅ Inside pipe diameter

1 Burner

2 Pump

3 Filter

4 Manual on/off valve

5 Suction line

6 Foot valve

7 Rapid closing manual valve remote controlled (only Italy)

8 On/off solenoid valve (only Italy)

11 Tank filter

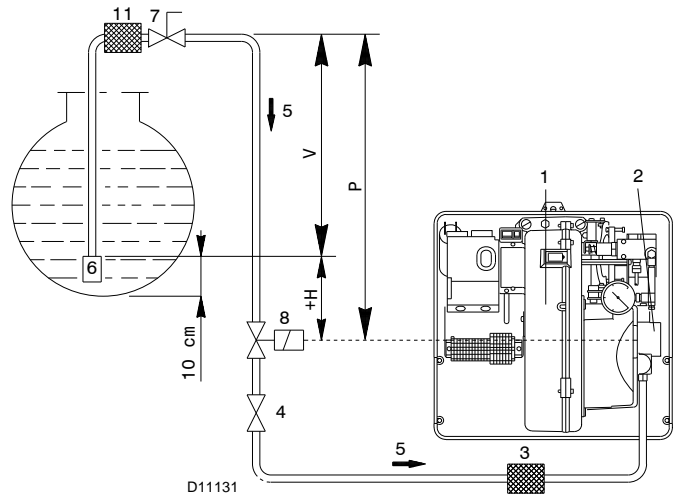

Fig. 14

+/- H (meters)	L (meters)					
	RL 28/M			RL 38-50/M		
	∅ mm			∅ mm		
	10	12	14	10	12	14
+ 4,0	63	144	150	51	112	150
+ 3,0	55	127	150	45	99	150
+ 2,0	48	111	150	39	86	150
+ 1,0	40	94	150	32	73	144
+ 0,5	37	86	150	29	66	132

Tab. G

5.11 Hydraulic connections

The pumps are equipped with a by-pass that connects return line with suction line. The pumps are installed on the burner with the by-pass closed by screw 6)(Fig. 16).

It is therefore necessary to connect both hoses to the pump.

The pump will break down immediately if it is run with the return line closed and the by-pass screw inserted.

Remove the plugs from the suction and return connections of the pump.

Insert the hose connections with the supplied seals into the connections and screw them down.

Take care that the hoses are not stretched or twisted during installation.

Route the hoses through the holes in the plate, preferably using those on the rh side, (Fig. 15):

- unscrew the screws 1), now divide the insert piece into its two parts 2) and 3);
- remove the thin diaphragm blocking the two passages 4).
- Install the hoses where they cannot be stepped on or come into contact with hot surfaces of the boiler.
- Now connect the other end of the hoses to the suction and return lines by using the supplied nipples.

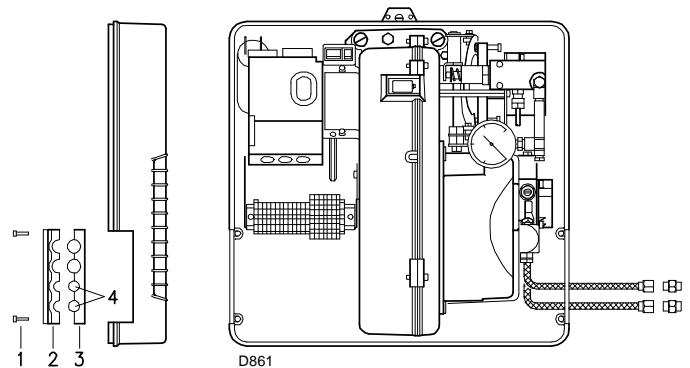

Fig. 15

5.12 Pump



In case of use with gas oil containing up to 10% Bio blend, it will be essential to use flexible oil lines suitable for bio fuel use. Please contact Riello for further information.

RL 28/M SUNTEC ALV75C
RL 38-50/M SUNTEC ALV95C

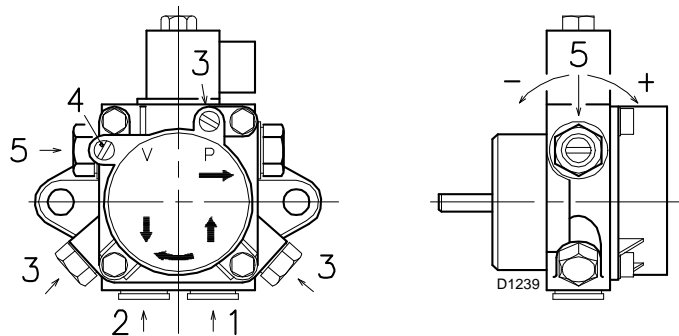

Fig. 16

- 1 Suction G 1/4"
- 2 Return G 1/4"
- 3 Pressure gauge attachment G 1/8"
- 4 Vacuum meter attachment G 1/8"
- 5 Pressure governor

5.12.1 Technical data

		ALV75C	ALV95C
A	kg/h	74	99
B	bar	10 - 20	10 - 20
C	bar	0,45	0,45
D	cSt	2 - 12	2 - 12
E	°C	60	60
F	bar	2	2
G	bar	20	20
H	mm	0,150	0,150

Tab. H

Key (Tab. H)

- A Min. delivery rate at 20 bar pressure
- B Delivery pressure range
- C Max. suction depression
- D Viscosity range
- E Max light oil temperature
- F Max. suction and return pressure
- G Pressure calibration in the factory
- H Filter mesh width

5.12.2 Pump priming



Before starting the burner, make sure that the tank return line is not clogged.

Obstructions in the line could cause the sealing organ located on the pump shaft to break. (The pump leaves the factory with the by-pass closed).

- Also check to make sure that the valves located on the suction line are open and that there is sufficient fuel in the tank.
- For self-priming to take place, one of the screws 3)(Fig. 16) of the pump, must be loosened in order to bleed off the air contained in the suction line.
- Start the burner by closing the control devices with switch 1)(Fig. 17) in the "MAN" position. As soon as the burner starts, check the direction of rotation of the fan blade, by looking through the flame inspection window 19)(Fig. 4 at page 12).
- The pump can be considered primed when the light oil starts coming out of the screw 3)(Fig. 16). Stop the burner: switch 1)(Fig. 17) set to "OFF" and tighten the screw 3).

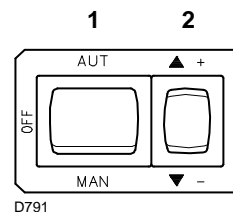

Fig. 17

The time required for this operation depends upon the diameter and length of the suction tubing.

If the pump fails to prime at the first starting of the burner and the burner locks out, wait approx. 15 seconds, reset the burner, and then repeat the starting operation as often as required.

After 5 or 6 starting operations allow 2 or 3 minutes for the transformer to cool.



The a.m. operation is possible because the pump is already full of fuel when it leaves the factory.

If the pump has been drained, fill it with fuel through the opening on the vacuum meter prior to starting; otherwise, the pump will seize.

Whenever the length of the suction piping exceeds 20 - 30 meters, the supply line must be filled using a separate pump.

6 Electrical system

6.1 Notes on safety for the electrical wiring



- The electrical wiring must be carried out with the electrical supply disconnected.
- Electrical wiring must be carried out by qualified personnel and in compliance with the regulations currently in force in the country of destination. Refer to the wiring diagrams.
- The manufacturer declines all responsibility for modifications or connections different from those shown in the wiring diagrams.
- Do not invert the neutral with the phase in the electrical supply line. Any inversion would cause a lockout due to firing failure.
- Check that the electrical supply of the burner corresponds to that shown on the identification label and in this manual.
- The burners have been set for intermittent operation. This means they should compulsorily be stopped at least once every 24 hours to enable the control box to perform checks of its own start-up efficiency. Normally the boiler's thermostat/pressure switch ensures the stopping of the burner.
If this is not the case, it is necessary to apply in series with IN a timer switch that turns off the burner at least once every twenty-four hours. Refer to the wiring diagrams.
- The electrical safety of the device is obtained only when it is correctly connected to an efficient earthing system, made according to current standards. It is necessary to check this fundamental safety requirement. In the event of doubt, have the electrical system checked by qualified personnel.
- The electrical system must be suitable for the maximum input power of the device, as indicated on the label and in the manual, checking in particular that the section of the cables is suitable for the input power of the device.
- For the main power supply of the device from the electricity mains:
 - do not use adapters, multiple sockets or extensions;
 - use an omnipolar switch, as indicated by the current safety standards.
- Do not touch the device with wet or damp body parts and/or in bare feet.
- Do not pull the electric cables.

Before carrying out any maintenance, cleaning or checking operations:



disconnect the electrical supply from the burner by means of the main system switch;



isolate the fuel supply.

If the cover is still present, remove it and proceed with the electrical wiring according to the wiring diagrams.

6.2 Electrical connections



Electrical wiring must be made in accordance with the regulations currently in force in the country of destination and by qualified personnel.

Riello S.p.A. declines all liability for modifications or connections other than those shown on these diagrams.

Use flexible cables according to regulations EN 60 335-1:

- if in PVC boot, use at least H05 VV-F;
- if in rubber boot, use at least H05 RR-F.

All the cables to be connected to the burner terminal strip 5)(Fig. 18) must be routed through the fairleads, supplied by the manufacturer for insertion into the holes in the plate, preferably those on the left side, after having unscrewed screws 6), split the plate into its two parts 7) and 8) then removed the thin diaphragm effectively closing the aperture.

The fair leads and precut holes can be used in various ways. One example is given below (Fig. 18):

RL 28/M

- 1 Pg 11 Single phase power supply
- 3 Pg 9 Control device TL
- 4 Pg 9 Control device TR or probe (RWF40)

RL 38-50/M

- 1 Pg 11 Three phase power supply
- 2 Pg 11 Single phase power supply
- 3 Pg 9 Control device TL
- 4 Pg 9 Control device TR or probe (RWF40)

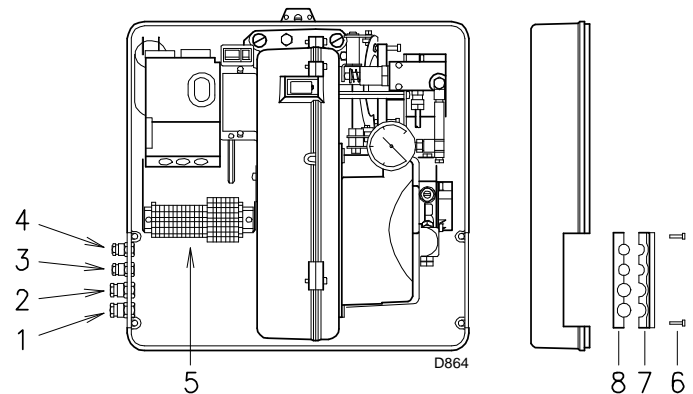

Fig. 18

6.3 Calibration of thermal relay

This is required to avoid motor burn-out in the event of a significant increase in power absorption caused by a missing phase.

- If the motor is star-powered, **400V**, the cursor should be positioned on "MIN".
- If the motor is delta-powered, **230V**, the cursor should be positioned on "MAX".

Even if the scale of the thermal cut-out does not include rated motor absorption at 400V, protection is still ensured in any case.

NOTA

Burners RL 38-50/M leave the factory preset for 400V power supply.

If 230V power supply is used, change the motor connection from star to delta and change the setting of the thermal cutout.

The burners are also fitted for continuous operation, if they are equipped with control box LANDIS type LOK 16.250 A27 (interchangeable with the burner control box LANDIS LAL 1.25).

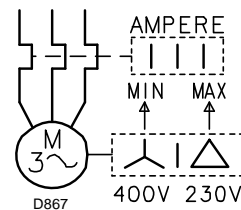

Fig. 19



- Do not invert the neutral with the phase wire in the electricity supply line. Any inversion would cause a lockout due to firing failure.
- Only use original spare parts to replace the components.

7 Start-up, calibration and operation of the burner

7.1 Notes on safety for the first start-up



The first start-up of the burner must be carried out by qualified personnel, as indicated in this manual and in compliance with the standards and regulations of the laws in force.



Check the correct working of the adjustment, command and safety devices.

7.2 Burner firing

Close load controls and set switch 1)(Fig. 20) to "MAN".
After burner firing a complete burner adjustment should be performed.

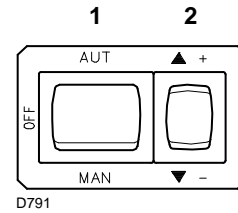

Fig. 20

7.3 Burner calibration

The optimum calibration of the burner requires an analysis of the flue gases at the boiler outlet.

Adjust successively:

- Combustion head
- Servomotor
- MAX burner output
- MIN burner output
- Intermediate outputs between MAX and MIN output

7.3.1 Combustion head setting

The setting of the combustion head depends exclusively on the maximum burner delivery at which it will be operating.

Turn screw 4)(Fig. 21) until the notch shown in diagram (Fig. 22) is level with the front surface of flange 5)(Fig. 21).

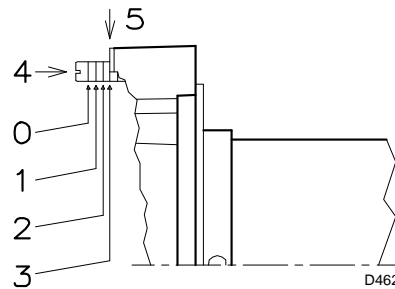

Fig. 21

Example:

RL 50/M, maximum light oil delivery = 32 kg/h.
Diagram (Fig. 22) indicates that for a delivery of 32 kg/h the burner requires the combustion head to be set to approx. three notches, as shown in Fig. 21.

7.3.2 Servomotor

The servomotor (Fig. 23) provides simultaneous adjustment of the air gate valve 11)(Fig. 24 at page 23) and the pressure regulator 9) by means of a double variable profile cam, 4) and 7).

The servomotor rotates through 90° in 24 seconds.

Do not alter the factory setting for the 4 cams; simply check that they are set as indicated below:

- Cam I:** 90°
Limits rotation toward maximum position.
- Cam II:** 0°
Limits rotation toward the minimum position. When the burner is shut down the air gate valve must be closed: 0°.
- Cam III:** 15°
Adjusts the ignition position and the MIN output.
- Cam IV:** not utilized.

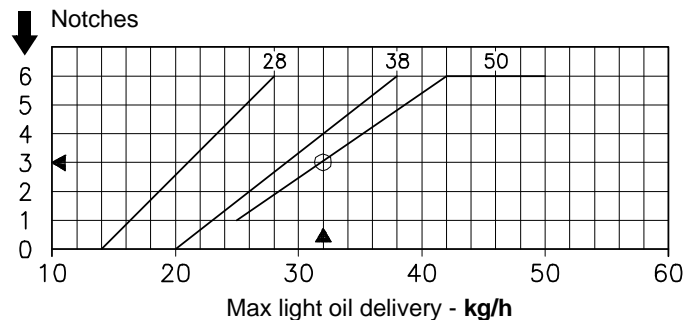

Fig. 22

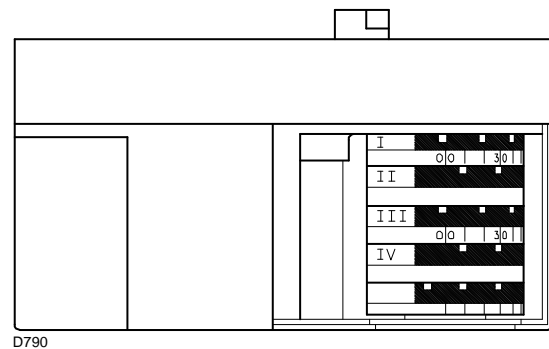

Fig. 23

7.3.3 MAX power

Max output of the burner must be set within the firing rate range shown on page 11.

In the above instructions we left the burner running in MIN output operation. Now press button 2)(Fig. 20 at page 22) “+” until servomotor arrives at 90°.

Adjusting the nozzle flow rate

The nozzle flow rate varies according to the fuel pressure on the nozzle return.

Diagram (Fig. 25) indicates this relationship for type A3 Bergonzo nozzles with pump delivery pressure of 20 bar.

NOTE

With a pump delivery pressure of 20 bars, the pressure on the nozzle return must not exceed 17 bar.

The pressure difference between pump delivery and nozzle return must be at least 3 bars. With smaller pressure differences, the pressure on the nozzle return can be unstable.

To fix the maximum nozzle flow rate, vary the final profile on the upper cam 7)(Fig. 24) via the screws 8).

The nozzle return pressure value is indicated by the pressure gauge 10).

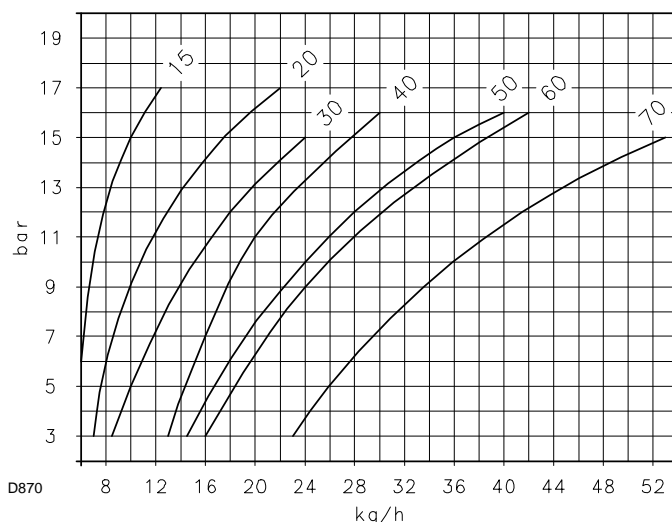

Fig. 25

Key (Fig. 25)
Horizontal axis: kg/h, nozzle flow rate
Vertical axis: bar, nozzle return pressure

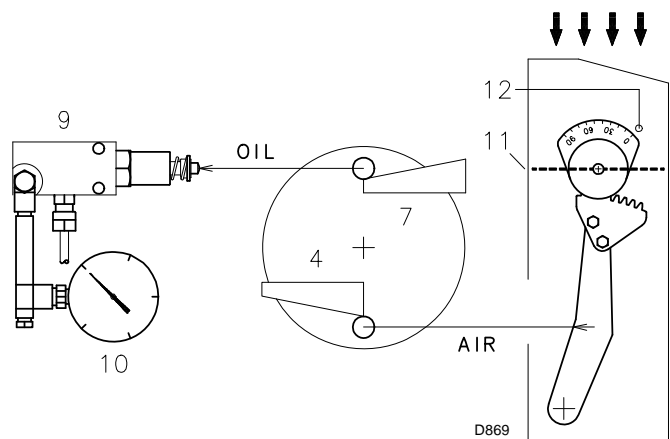
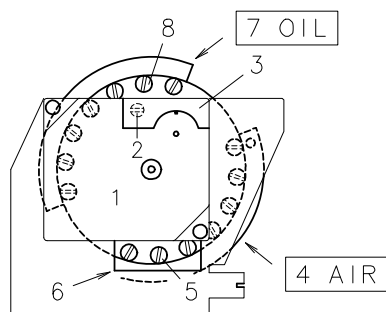

Fig. 24

Key (Fig. 24)

- 1 Servomotor
- 2 Cams 4) - 7) engaged ⊖ / disengaged ⊕
- 3 Servomotor cams cover
- 4 Cam for controlling air gate valve
- 5 Cam 4) adjustable screws
- 6 Opening for access to screws 5)
- 7 Cam for controlling pressure regulator
- 8 Cam 7) adjustable screws
- 9 Pressure regulator
- 10 Gauge for pressure on nozzle return
- 11 Air gate valve
- 12 Index

Adjusting air delivery

Two shutters 1) and 2)(Fig. 26) are provided to adjust the air. These shutters are factory set to maximum opening.

Firstly adjust shutter 2) which must be closed gradually until optimum combustion is obtained.

If total closure of shutter 2) is not sufficient, also close shutter 1) (secondly) as follows:

- vary the final profile of the lower cam 4)(Fig. 24) via the screws 5) inside the opening 6).

If the burner is operated at maximum power, the fan air may not be sufficient even with both shutters 1) and 2) fully open.

In this case, remove shutter 2) and adjust the air using shutter 1) only as described above.

Cams 7)-4)(Fig. 24):

- tighten screws 8)-5) to increase air delivery
- unscrew screws 8)-5) to reduce air delivery

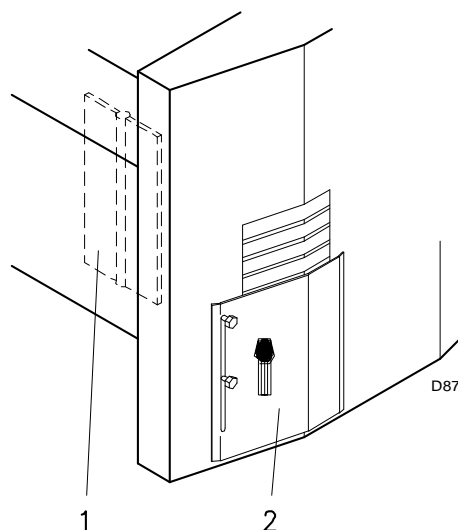

Fig. 26

7.3.4 MIN power

The MIN power must be chosen from within the working range given on page 11.

Press the “-” button 2)(Fig. 20 at page 22) and keep it pressed until the servomotor has reached 15° (factory setting).

Nozzle flow rate adjustment

The nozzle flow rate is given in diagram (Fig. 25 at page 23) corresponding to the pressure on the nozzle return read on the pressure gauge 10)(Fig. 24 at page 23).

To vary the nozzle minimum flow rate, modify the initial profile of the upper cam 7)(Fig. 24 at page 23) via the screws 8).

Adjusting air delivery

Modify the initial profile of the lower cam 4)(Fig. 24 at page 23) via the screws 5) inside the opening 6).

If possible, do not rotate the first screw as this is the one that provides for total closure of the air shutter.

7.3.5 Intermediate power

Air/oil flow rate adjustment

Slightly press the “+” button 2)(Fig. 20 at page 22) so that a new screw 5)(Fig. 24 at page 23) appears inside the opening 6).

Adjust screw 8) which varies the profile of the upper cam 7) and the corresponding screw 5) which controls the lower cam 4) until you obtain optimum combustion.

Proceed in the same way with the next screws except for the last one, previously adjusted to obtain maximum power.

Ensure that variation of the cams profile is gradual.

Turn the burner off via switch 1)(Fig. 20 at page 22), OFF position, release the cam with variable profile by setting the servomotor notch 2)(Fig. 24 at page 23) to the vertical position and check that the movement is smooth by manually rotating the cam backwards and forwards several times.

NOTE

Cams I - II - IV of the servomotor do not require adjustment. Only cam III may need adjusting. In this case, remove the cover 1)(Fig. 27), which clicks in and out, take the key 2) out and insert it in the notch on cam III.

The servomotor follows the adjustment of cam III only when the cam angle is reduced.

If you need to increase the cam angle (15..16..17°..), first increase the servomotor angle via the “+” button, then increase the angle of cam III and finally reset the servomotor to the MIN power position via the “-” button.

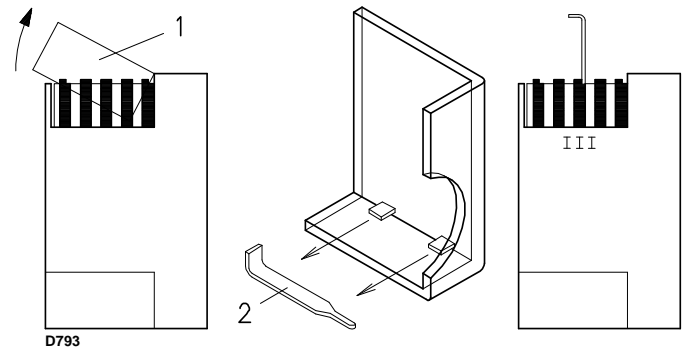

Fig. 27

7.4 Oil pressure switch

The oil pressure switch 14)(Fig. 29 at page 25) is factory set to 3 bar.

If the gas oil pressure reaches this value in the return piping, the pressure switch stops the burner.

Burner starts again automatically if the pressure goes down under 3 bar after burner shut down.

If a loop circuit (page 17) with Px pressure feeds the burner, the pressure switch should be adjusted to Px + 3 bar.

7.5 Burner operation

7.5.1 Burner starting

- 0 s:** Control device TL closes, the motor starts.
The pump 3)(Fig. 29) sucks the fuel from the tank through the piping 1) and the filter 2) and pumps it under pressure to delivery.
The piston 4) rises and the fuel returns to the tank through the piping 5) - 7).
The screw 6) closes the by-pass heading towards suction and the de-energized solenoid valves 8) - 15) - 16) close the passage to the nozzle.
- 5 s:** Servomotor starts: 90° rotation to right, until contact is made on cam I)(Fig. 23 at page 22).
The air gate valve is positioned on MAX. output.
- 29 s:** Pre-purge stage with air delivery at MAX. output.
- 51 s:** Servomotor rotates to left until contact is made on cam III)(Fig. 23 at page 22).
- 71 s:** Air gate valve and pressure regulator are positioned on MIN output.
- 72.5 s:** Ignition electrode strikes a spark.
- 75 s:** Solenoid valves 8) - 15) - 16) open; the fuel passes through the piping 9) and filter 10), finally it enters the nozzle.
A part of the fuel is then sprayed out through the nozzle, igniting when it comes into contact with the spark: flame at a low output level, point A; the rest of the fuel passes through piping 11) at the pressure adjusted by the regulator 12), then, through piping 7), it goes back into the tank.
- 80 s:** The spark goes out.
- 90 s:** The starting cycle ends.

7.5.2 Steady state operation

Burner without output regulator RWF40

At the end of the starting cycle, the servo-motor control then passes to load control TR for boiler pressure or temperature, point B.

- If the temperature or pressure is low (and the TR load control is consequently closed), the burner progressively increases output up to MAX (section B-C).
- If subsequently the temperature or pressure increases until TR opens, the burner progressively decreases output down to MIN (section D-E). And so on.
- The burner locks out when demand for heat is less than the heat supplied by the burner in the MIN output (section F-G). Load control TL opens. The servomotor returns to the 0° angle limited by contact with cam II)(Fig. 23 at page 22).
The gate valve closes completely to reduce thermal dispersion to a minimum.

Every time output is changed, the servomotor automatically modifies gas oil delivery (pressure regulator) and air delivery (fan gate valve).

Burner with output regulator RWF40

See the handbook enclosed with the regulator.

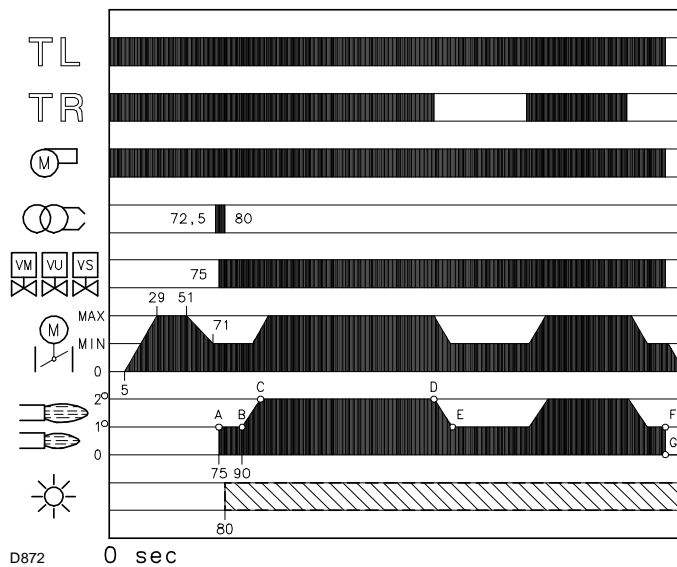

Fig. 28

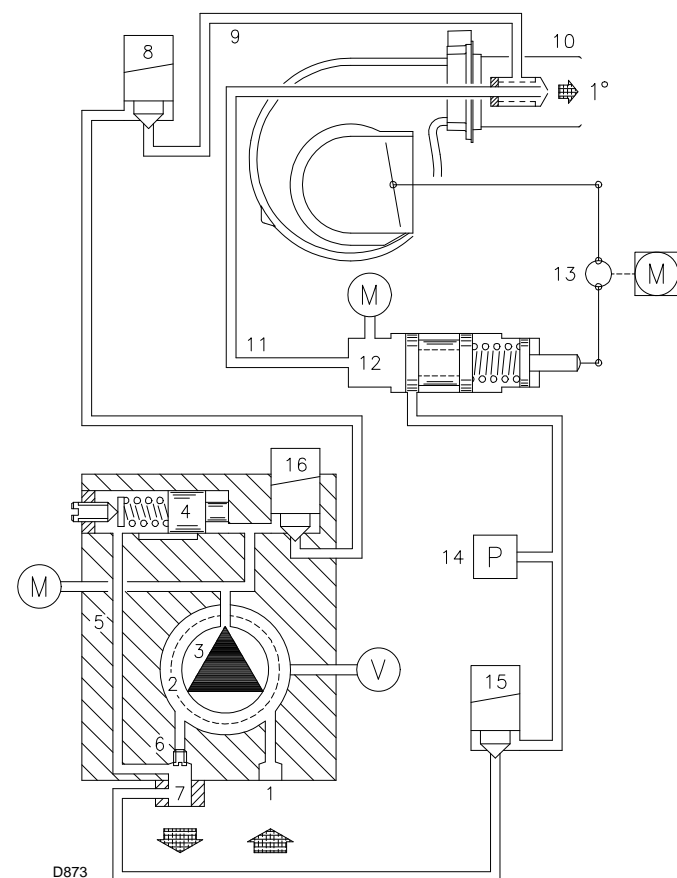

Fig. 29

7.5.3 Firing failure

If the burner does not fire, it goes into lock-out within 5 s of the opening of the light oil valve.

7.5.4 Firing failure

If the flame should go out for accidental reasons during operation, the burner will lock out in 1 s.

7.6 Final checks

- Obscure the photocell and switch off the control devices:
the burner should start and then lock-out about 5 s after starting.
- Illuminate the photocell and switch off the control devices:
burner should go into lock-out.
- Obscure the photocell while the burner is operating:
flame should go out and burner lock out within 1 s.
- Switch on control device TL followed by control device TS
while the burner is operating:
the burner should stop.

8 Maintenance

8.1 Notes on safety for the maintenance

The periodic maintenance is essential for the good operation, safety, yield and duration of the burner.

It allows you to reduce consumption and polluting emissions and to keep the product in a reliable state over time.



The maintenance interventions and the calibration of the burner must only be carried out by qualified, authorised personnel, in accordance with the contents of this manual and in compliance with the standards and regulations of current laws.

Before carrying out any maintenance, cleaning or checking operations:



Disconnect the electrical supply from the burner by means of the main system switch.



Close the fuel interception tap.

8.2 Maintenance programme

8.2.1 Maintenance frequency

The combustion system should be checked at least once a year by a representative of the manufacturer or another specialised technician.

8.2.2 Checking and cleaning

Combustion

The optimum calibration of the burner requires an analysis of the flue gases.

Significant differences with respect to the previous measurements indicate the points where more care should be exercised during maintenance.

Combustion head

Check to make sure that all the parts of the combustion head are in good condition, positioned correctly, free of all impurities, and that no deformation has been caused by operation at high temperatures.

Photocell

Clean the glass cover from any dust that may have accumulated. Photocell 1 (Fig. 30) is held in position by a pressure fit and can therefore be removed by pulling it outward forcefully.

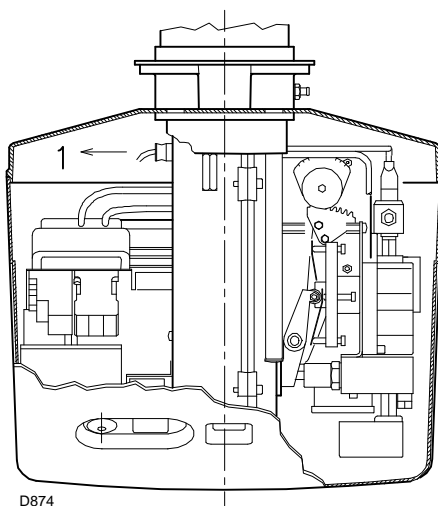

D874

Fig. 30

Burner

Check for excess wear or loose screws. Also make sure that the screws securing the electrical leads in the burner connections are fully tightened.

Clean the outside of the burner.

Servomotor

Disengage servomotor by turning slot 2 (Fig. 24 at page 23) through 90° and turn it backward and forward by hand to make sure it is free moving.

Fan

Check to make sure that no dust has accumulated inside the fan or on its blades, as this condition will cause a reduction in the air flow rate and provoke polluting combustion.

Boiler

Clean the boiler as indicated in its accompanying instructions in order to maintain all the original combustion characteristics intact, especially the flue gas temperature and combustion chamber pressure.

Flame inspection window

Clean the glass (Fig. 31).

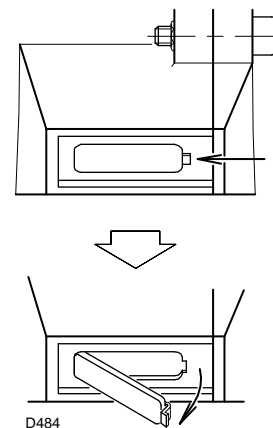

D484

Fig. 31

Filters

Check the filtering baskets on line and at nozzle present in the system. Clean or replace if necessary.

If rust or other impurities are observed inside the pump, use a

separate pump to lift any water and other impurities that may have deposited on the bottom of the tank.

Pump

The delivery pressure must be stable. The depression must be less than 0.4 bar. Unusual noise must not be evident during pump operation.

If the pressure is found to be unstable or if the pump runs noisily, the flexible hose must be detached from the line filter and the fuel must be sucked from a tank located near the burner. This measure permits the cause of the anomaly to be traced to either the suction piping or the pump.

If the pump is found to be responsible, check to make sure that the filter is not dirty. The vacuum gauge is installed upstream from the filter and consequently will not indicate whether the filter is clogged or not. Contrarily, if the problem lies in the suction line, check to make sure that the filter is clean and that air is not entering the piping.

Please check that the supply line and filters are clear. The use of a pump vacuum gauge will assist in this. This measure permits the cause of the anomaly to be traced to either the suction line or the pump.

If the problem lies in the suction line, check to make sure that the filter is clean and that air is not entering the piping.

Hoses

- Check periodically the flexible pipes conditions. They have to be replaced at least **every 2 years**.
- In case of use of gas oil and bio fuel blends, it is strongly recommended to inspect **even more frequently** the hoses and replace them where contamination has occurred.
- Check to make sure that the hoses are still in good condition.

Nozzles

Do not clean the nozzle openings; do not even open them. The nozzle filters however may be cleaned or replaced as required. It is advisable to replace nozzles every year during regular maintenance operations. Combustion must be checked after the nozzles have been changed.

Fuel tank

If water or contamination is present within the fuel tank, it is essential that this is removed before the equipment is to be used. This is extremely important when gas oil containing Bio diesel is in use. If in doubt about how to achieve this then please contact the fuel or oil tank supplier.

Combustion

In case the combustion values found at the beginning of the intervention do not respect the standards in force or, in any case, do not correspond to a proper combustion, contact the Technical Assistant and have him carry out the necessary adjustments.

EN 267	Excess air		
	Max output $\lambda \leq 1.2$		Min output $\lambda \leq 1.3$
Theoretical max. CO ₂ 0 % O ₂	Calibration CO ₂ %		CO mg/kWh
15.2	$\lambda = 1,2$	$\lambda = 1,3$	≤ 100
	12.6	11.5	

8.2.3 Fuel pump and/or couplings replacement

Carry out in conformity with Fig. 32.

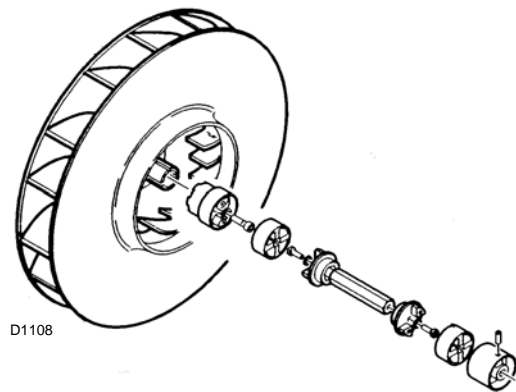

Fig. 32

8.3 Opening the burner



Disconnect the electrical supply from the burner.

- Remove screw 1)(Fig. 33) and withdraw the casing 2).
- Unscrew screw 3).
- Fit the two extensions 4) supplied with the burner onto the slide bars 5) (models with 351 mm blast tube).
- Pull part A backward keeping it slightly raised to avoid damaging the disk 6) on blast tube 7).

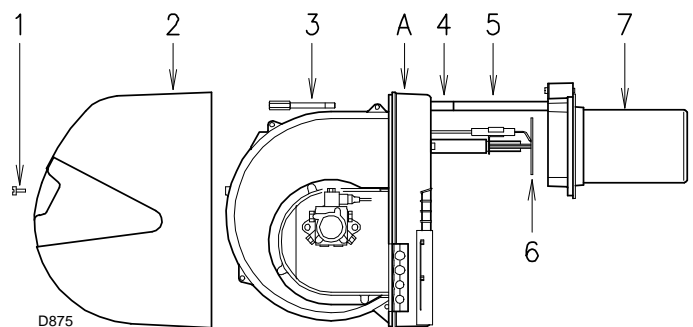

Fig. 33

9 Faults - Possible causes - Solutions

Find a list of faults, causes and possible solutions for a set of failures that may occur and result in irregular burner operation or no functioning at all.

If a burner malfunction is detected, first of all:

- check that the electrical wiring is adequately connected;
- check whether fuel is delivered;
- check that every adjustment parameter is adequately set.

SYMBOL (1)	FAULT	PROBABLE CAUSE	SUGGESTED REMEDY
◀	The burner does not start	A limit or safety control device is open	Adjust or replace
		Control box lock-out	Reset control box
		Oil pressure switch intervenes	Adjust pressure switch or eliminate overpressure
		Motor protection tripped (RL 38-50/M)	Reset thermal cut-out
		No electrical power supply	Close all switches - Check connections
		Control box fuse blown	Replace (2)
		Contact II of servomotor does not operate, control box terminals 11 - 8	Adjust cam II or replace servo-motor
		Pump is jammed	Replace
		Defective capacitor (RL 28/M)	Replace
		Defective motor command control device (RL 38-50/M)	Replace
	The burner does not start and a function lock-out occurs	Defective control box	Replace
		Defective electrical motor	Replace
		Flame simulation	Replace control box
		Photocell short-circuit	Replace photocell
	Missing phase (RL 38-50/M) thermal cut-out trips	Reset thermal cut-out when third phase is re-connected	
▲	The burner starts but stops at maximum air damper setting	Contact I of servomotor does not operate, control box terminals 9-8	Adjust cam I or replace servomotor
■	The burner starts and then goes into lock-out	Fault in flame detection circuit	Replace control box
▼	The burner remains in pre-purging phase	Contact III of servomotor does not operate, control box terminals 10-8	Adjust cam III or replace servomotor
1	After pre-purge and the safety time, the burner goes to lock-out and the flame does not appear	No fuel in tank; water on tank bottom	Top up fuel level or suck up water
		Inappropriate head and air damper adjustments	Adjust
		Light oil solenoid valves fail to open	Check connections; replace coil
		Nozzle clogged, dirty, or deformed	Replace
		Dirty or poorly adjusted firing electrodes	Adjust or clean
		Grounded electrode due to broken insulation	Replace
		High voltage cable defective or grounded	Replace
		High voltage cable deformed by high temperature	Replace and protect
		Ignition transformer defective	Replace
		Erroneous electrical connections of valves or transformer	Check
		Defective control box	Replace
		Pump unprimed	Prime pump and see "Pump unprimed" (54-55)
		Pump/motor coupling broken	Replace
		Pump suction line connected to return line	Correct connection
	Valves up-line from pump closed	Open	
	Filters dirty: line - pump - nozzle	Clean	
	Incorrect motor rotation direction	Change motor electrical connections	
	The flame ignites normally but the burner locks out when the safety time has elapsed	Defective photocell or control box	Replace photocell or control box
Dirty photocell		Clean	
Firing with pulsations or flame detachment, delayed firing	Poorly adjusted head	Adjust	
	Poorly adjusted or dirty firing electrodes	Adjust	
	Poorly adjusted fan air gate: too much air	Adjust	
	Nozzle unsuited for burner or boiler	See Nozzle Table	
	Defective nozzle	Replace	
	Inappropriate pump pressure	Adjust	
The burner does not pass to 2nd stage	Control device TR does not close	Adjust or replace	
	Defective control box	Replace	

SYMBOL (1)	FAULT	PROBABLE CAUSE	SUGGESTED REMEDY
	Uneven fuel supply	Check if cause is in pump or fuel supply system	Feed burner from tank located near burner
	Internally rusted pump	Water in tank	Suck water from tank bottom with separate pump
	Noisy pump, unstable pressure	Air has entered the suction line	Tighten connectors
		- Depression value too high (higher than 35 cm Hg):	
		Tank/burner height difference too great	Feed burner with loop circuit
		Piping diameter too small	Increase
		Suction filters clogged	Clean
		Suction valves closed	Open
		Paraffin solidified due to low temperature	Add additive to light oil
	Pump unprimes after prolonged pause	Return pipe not immersed in fuel	Bring to same height as suction pipe
		Air enters suction piping	Tighten connectors
	Pump leaks gas oil	Leakage from sealing organ	Replace pump
	Smoke in flame - dark Bacharach	Not enough air	Adjust head and fan gate
		Nozzle worn or dirty	Replace
		Nozzle filter clogged	Clean or replace
		Erroneous pump pressure	Adjust
		Flame stability disk dirty, loose, or deformed	Clean, tighten in place, or replace
		Boiler room air vents insufficient	Increase
	- yellow Bacharach	Too much air	Adjust head and fan gate
	Dirty combustion head	Nozzle or filter dirty	Replace
		Unsuitable nozzle delivery or angle	See recommended nozzles
		Loose nozzle	Tighten
		Impurities on flame stability disk	Clean
		Erroneous head adjustment or not enough air	Adjust, open air damper
		Blast tube length unsuited to boiler	Contact boiler manufacturer
I	During operation, the burner stops in lock out	Dirty or defective photocell	Clean or replace

- (1) When the burner does not fire or comes to a halt following a fault, the symbol which appears on control box 23)(Fig. 4 at page 12) indicates the type of problem.
- (2) The fuse is located in the rear part of the control box 23)(Fig. 4 at page 12). A pull-out fuse is also available as a spare part which can be fitted after breaking the tang on the panel which holds it in place.

A Appendix - Accessories (optional)

OUTPUT POWER REGULATOR KIT RWF 40

With the modulating operation, the burner continually adapts the power to the request for heat, ensuring great stability for the parameter controlled: temperature or pressure.

Two components should be ordered:

- the output regulator to install on the burner
- the probe to install on the heat generator

Parameter to control		Probe		Output power regulator	
	Range	Type	Code	Type	Code
Temperature	- 100...+ 500°C	PT 100	3010110	RWF40	3010212
Pressure	0...2.5 bar	Probe with output 4...20 µA	3010213		
	0...16 bar		3010214		

POTENTIOMETER KIT

Depending on the servomotor fitted to the burner, a three-pole potentiometer (1000 Ω) can be installed to check the position of the servomotor.

Burner	Code
RL 28-38-50/M	3010109

SPACER KIT

If burner head penetration into the combustion chamber needs reducing, varying thickness spacers are available, as given in the following table.

Burner	Code
RL 28-38-50/M	3010095

EXTENDED HEAD KIT

“Standard head” burners can be transformed into “extended head” versions, by using the special kit. The kits available for the various burners, giving the original and the extended lengths, are listed below.

Burner	Code
RL 28/M	3010120
RL 38/M	3010121
RL 50/M	3010122

HEAD KIT FOR REVERSE FLAME CHAMBER

In certain cases, the use of the burner on reverse flame boilers can be improved by using an additional cylinder.

Burner	Standard head (mm)	Extended head (mm)	Code
RL 28-38/M	319	429	3010178
RL 50/M	319	429	3010179

DEGASSING UNIT

It may occur that a certain amount of air is contained in the fuel sucked up by the pump.

This air may originate from the fuel itself as a consequence of de-pressurisation or air leaking past imperfect seals.

In double-pipe systems, the air returns to the tank from the return pipe; in single-pipe systems, the air remains in circulation causing pressure variations in the pump and burner malfunctions.

For this reason, we advise installing a degassing unit near the burner in single-pipe installations.

Degassing units are provided in two versions:

Degassing unit characteristics

Burner output	80 kg/h max
Fuel pressure	0.7 bar max
Ambient temperature	40 °C max
Fuel temperature	40 °C max
Attachment connectors (without filter)	FF G 1/4 tank side FM G 3/8 conic burner side
Attachment connectors (with filter)	FF G 3/8 tank side FM G3/8 conic burner side

CONNECTION FLANGE KIT

A kit is available for use where the burner opening on the boiler is of excessive diameter.

Burner	Code
RL 28-38-50/M	3010138

SOUND PROOFING BOX

If noise emission needs reducing even further, sound-proofing boxes is available.

Burner	Box type	Average noise reduction [dB(A)]	Code
RL 28-38-50/M	C1/3	10	3010403

B Appendix - Electrical panel layout

ELECTRICAL EQUIPMENT FACTORY-SET

RL 28/M

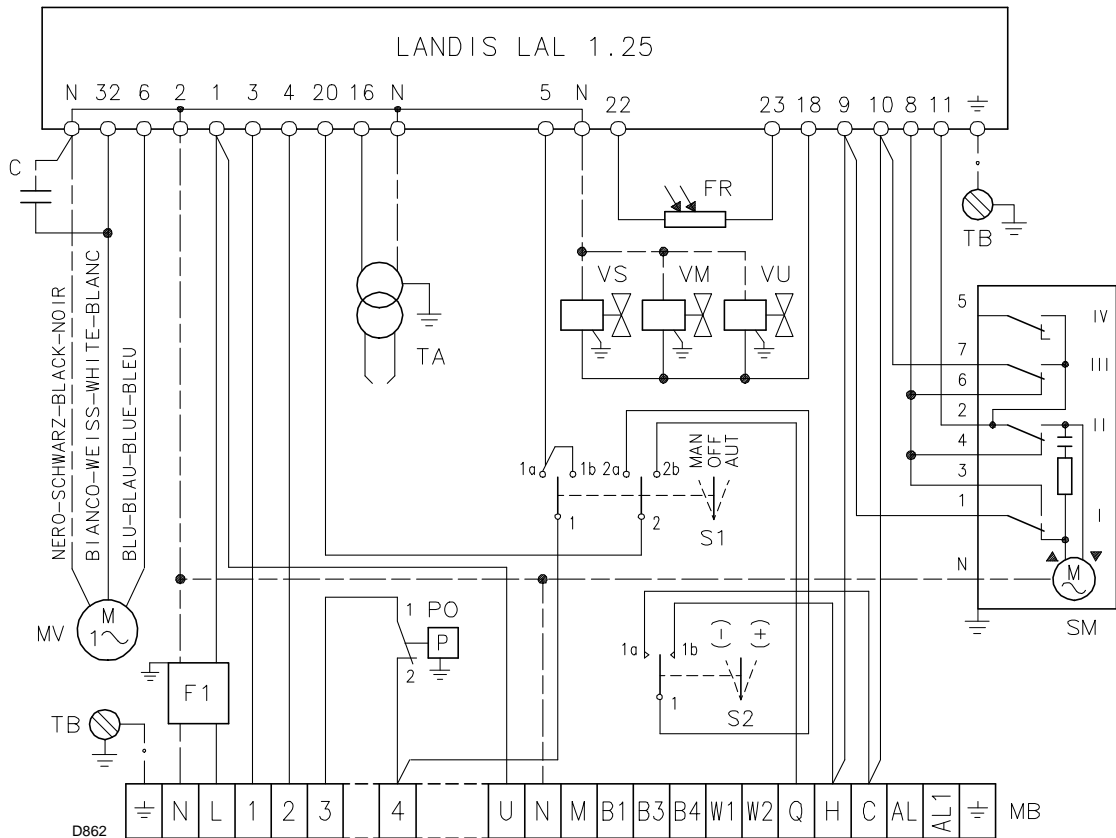

Fig. 1

RL 38-50/M

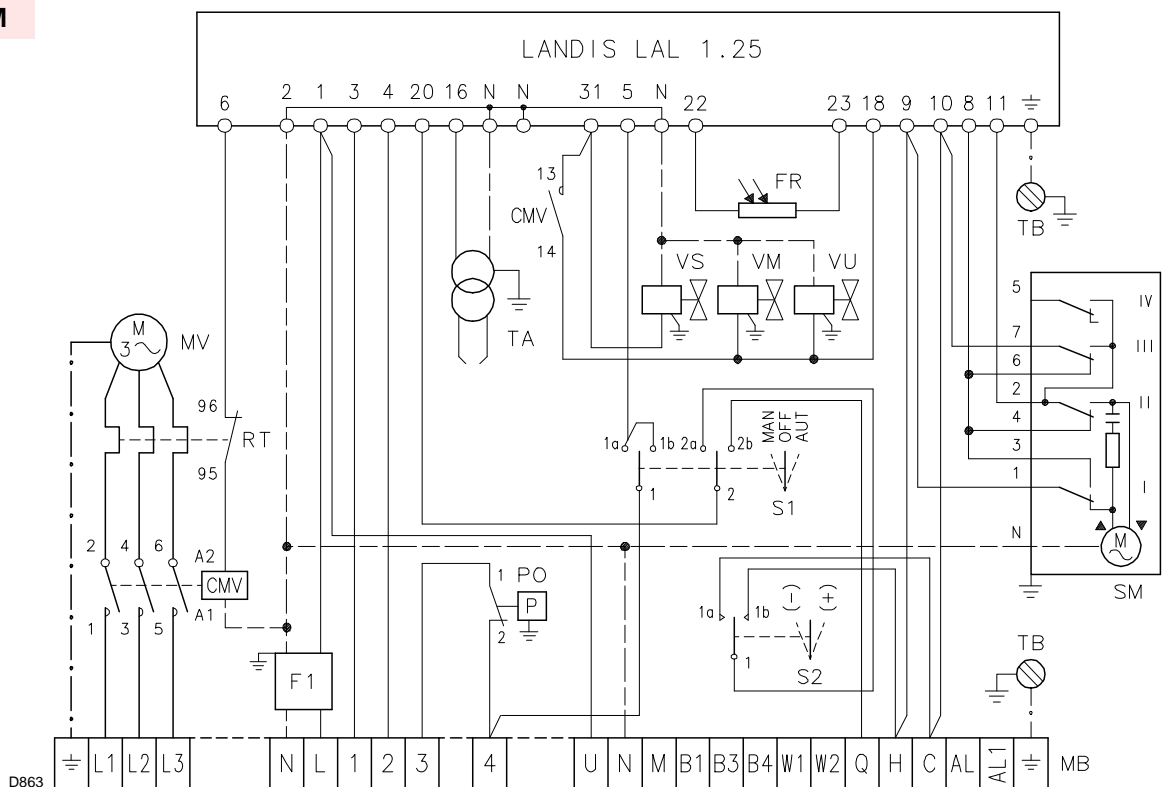

Fig. 2

Models **RL 38-50/M** leave the factory preset for **400V** power supply.

If **230V** power supply is used, change the motor connection from star to delta and change the setting of the thermal cut-out as well.



TO BE COMPLETED BY THE INSTALLER

RL 28/M

Electrical connection single-phase
230V power supply

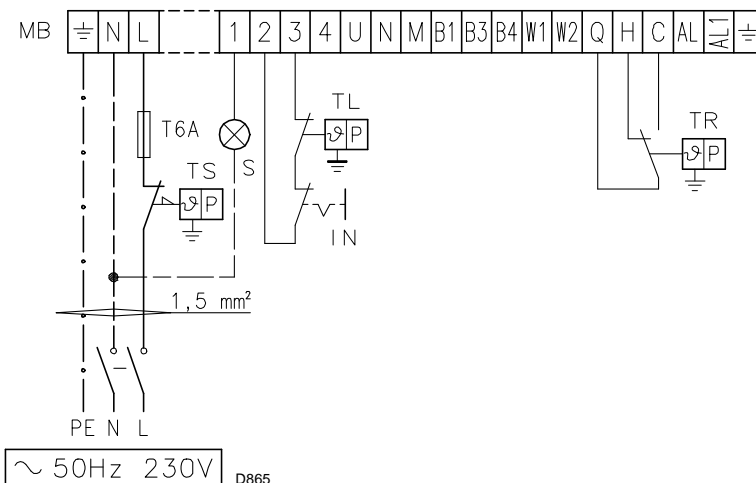

Fig. 3

RL 38-50/M

Electrical connection three-phase
230/400 V power supply

		RL 38/M		RL 50/M	
		230 V	400 V	230 V	400 V
F	A	T 6	T 6	T 6	T 6
L	mm ²	1,5	1,5	1,5	1,5

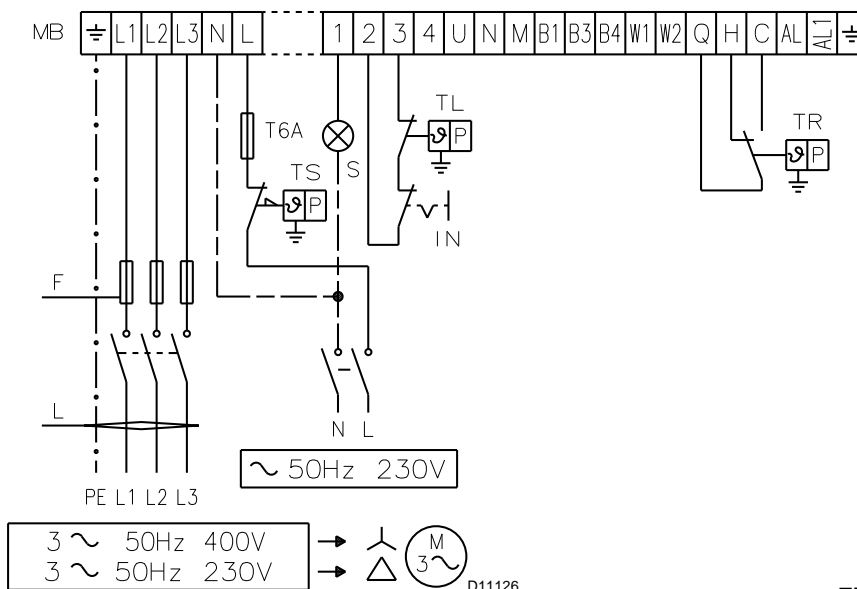

Fig. 4

RWF40

Power regulator RWF40 electrical
connection

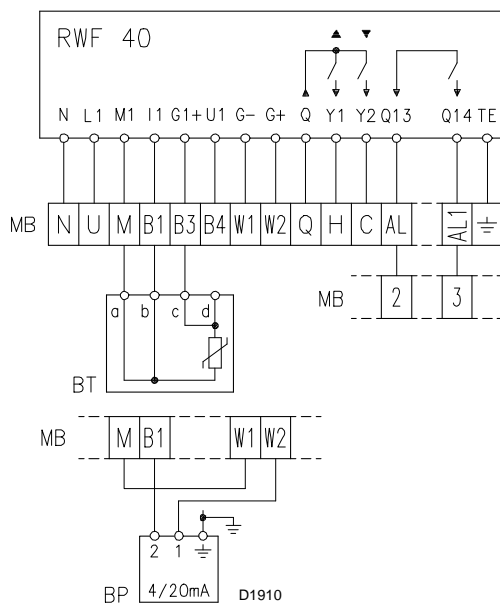

Fig. 5

Key to layout

a - d	rosso/rot/red/rouge
b - c	bianco/weiss/white/blanc
BP	Pressure probe
BT	Temperature probe
C	Capacitor
CMV	Motor contactor
LAL 1.25	Control box
F1	Protection against radio interference
FR	Photocell
IN	Manual burner stop switch
MB	Terminal strip
MV	Fan motor
PO	Oil pressure switch
RT	Thermal cut-out
S	Remote lock-out signal
S1	Switch for following operations : MAN = manual AUT = automatic OFF
S2	Button for : - = power reduction + = power increase
SM	Servomotor
TA	Ignition transformer
TB	Burner ground (earth) connection
TL	Limit control device system: this shuts down the burner when the boiler temperature or pressure exceeds the setpoint value.
TR	High-low mode control device system: controls operating stages 1 and 2. The TR load control is not required when the regulator RWF40 is connected as its function is performed by the regulator RWF40 itself.
TS	Safety control device system: this operates when TL is faulty
VM	Delivery pump valve
VS	Delivery pump valve (safety valve)
VU	Valve on nozzle return



RIELLO S.p.A.
I-37045 Legnago (VR)
Tel.: +39.0442.630111
[http:// www.rielloburners.com](http://www.rielloburners.com)